



FOR APPROVAL ONLY

NOT RELEASED FOR FABRICATION

REVISIONS		DATE	BY
B	UPDATE NOTES & TITLE BLOCK	10-14-19	CMJ
A	SUBMIT FOR APPROVAL	09-28-18	CMJ

STRUCTURAL NOTES:

- DESIGN SPECIFICATIONS:**
- ACI 318 BUILDING CODE REQUIREMENTS FOR STRUCTURAL CONCRETE
 - ASTM C857 STANDARD PRACTICE FOR MINIMUM STRUCTURAL DESIGN LOADING FOR UNDERGROUND PRECAST CONCRETE UTILITY STRUCTURES

- MATERIALS:**
- CONCRETE 28 DAY STRENGTH, $f_c = 6,000$ PSI
 - CONCRETE STRIPPING STRENGTH, $f_{ci} = 1,500$ PSI MIN
 - REBAR - ASTM A706 GRADE 60

- DESIGN CRITERIA:**
- LIVE LOAD = HS 20
 - HS 20 SURCHARGE = 80 PSF TO 8 FT BELOW GRADE
 - CONCRETE DENSITY = 150 PCF
 - SOIL DENSITY = 120 PCF
 - DRY SOIL LATERAL LOAD = 36 PCF
 - SATURATED SOIL LATERAL LOAD = 80 PCF
 - WATER TABLE DEPTH = 3 FT BELOW GRADE

- GENERAL NOTES:**
- CONTRACTOR SHALL:
 - GROUT AND/OR SEAL ALL JOINTS AS REQUIRED
 - VERIFY ALL DIMENSIONS AND OPENING LOCATIONS
 - DO NOT BACKFILL UNTIL STRUCTURE HAS BEEN COMPLETELY ASSEMBLED
 - TOLERANCES ARE PER ASTM C858
 - CUSTOMER RESPONSIBLE FOR PROVIDING ADEQUATE BEARING SURFACE, SLURRY/CLSM RECOMMENDED WITH 125 PSI COMPRESSIVE STRENGTH

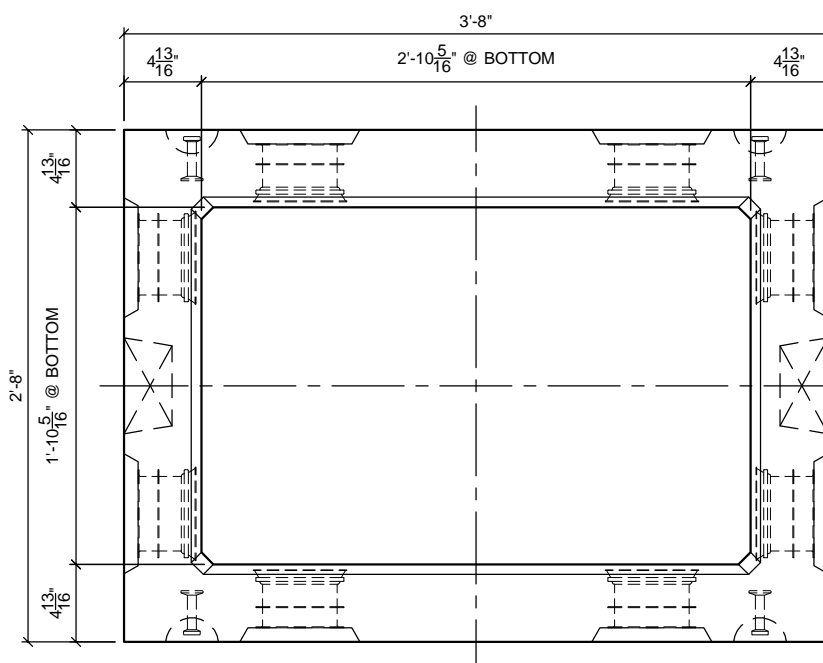

PLAN VIEW BASE

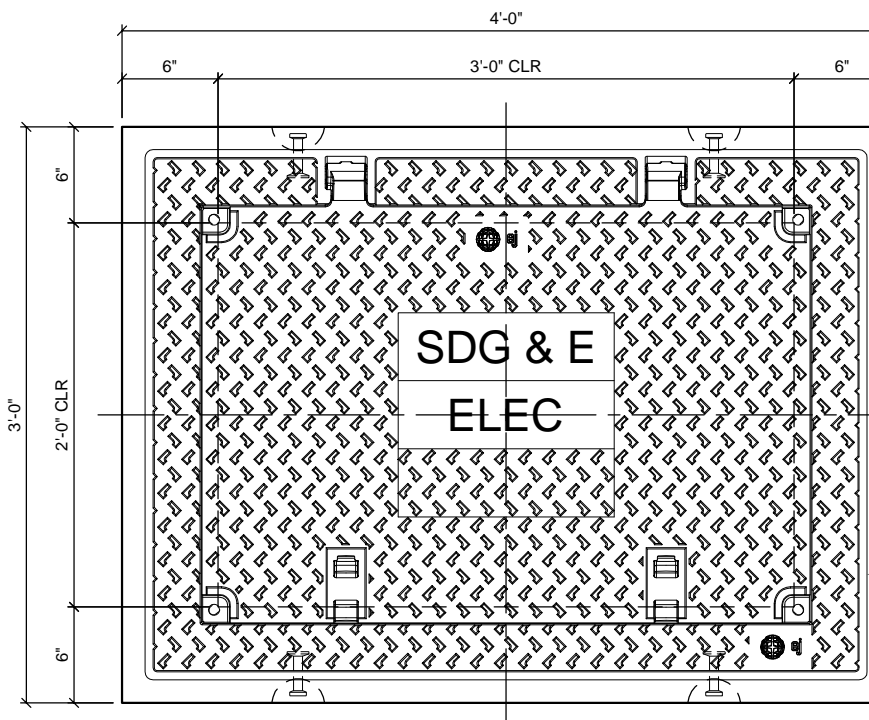

PLAN VIEW TOP

DIT Electric
S286752

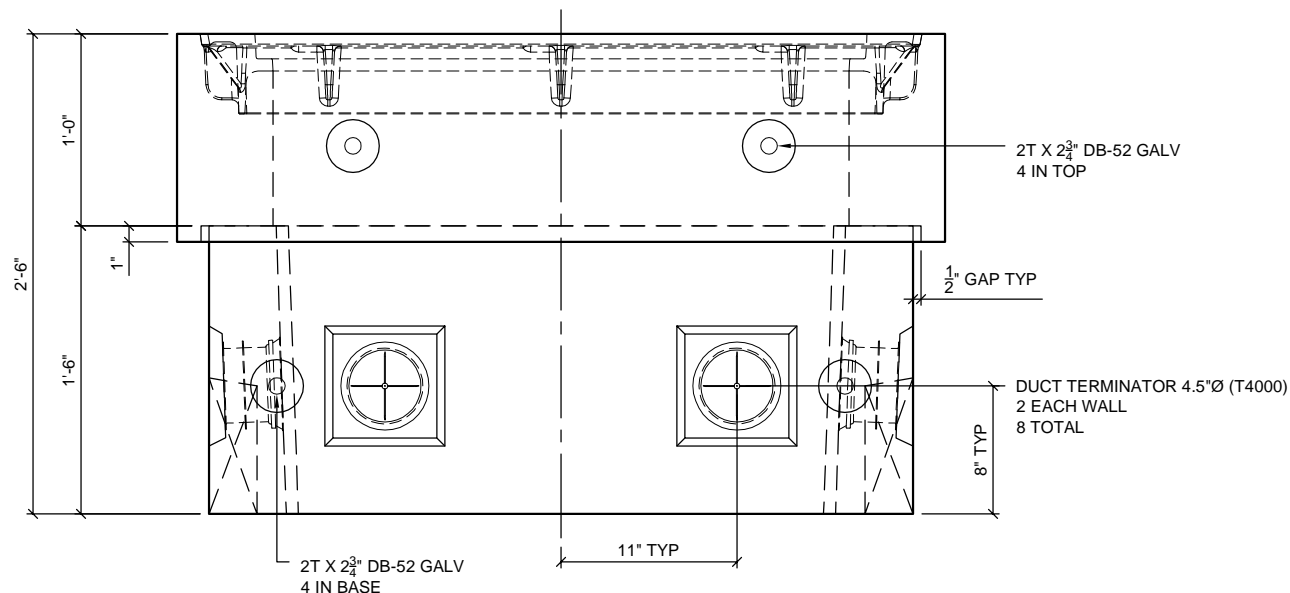

VIEW A

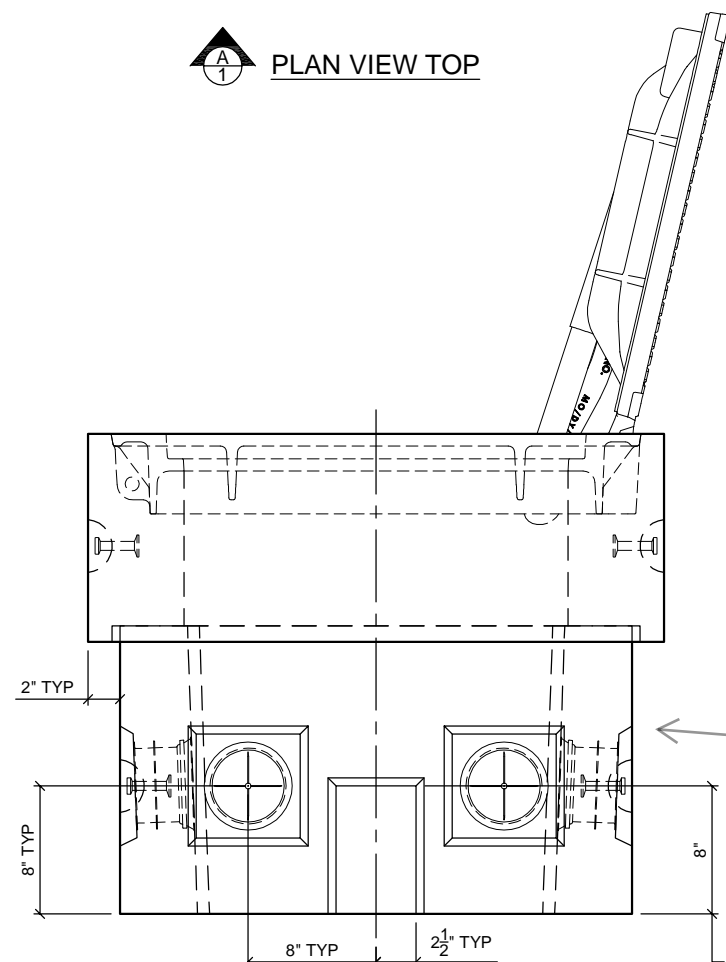

VIEW B

3313-L
S286754

INDEX OF DRAWINGS

COMPONENT	DRAWING			ITEM #
	FORM I.D.	WEIGHT LBS	CYD	
COMPLETE ASSEMBLY	070-X013053-001			
		1,799	0.44	
TOP	070-X013053-002			
	NO FORM	921	0.23	
BASE	070-X013047-002			
	SD-011	878	0.22	

Oldcastle Infrastructure
A CRH COMPANY
10650 HEMLOCK AVENUE FONTANA, CA 92337
P 800.626.3860 | F 909.350.8518

THIS DOCUMENT IS THE PROPERTY OF OLDCASTLE INFRASTRUCTURE, INC. IT IS CONFIDENTIAL, SUBMITTED FOR REFERENCE PURPOSES ONLY AND SHALL NOT BE USED IN ANY WAY INJURIOUS TO THE INTERESTS OF, OR WITHOUT THE WRITTEN PERMISSION OF OLDCASTLE INFRASTRUCTURE, INC. COPYRIGHT © 2019 OLDCASTLE INFRASTRUCTURE, INC. ALL RIGHTS RESERVED.

2'-0" X 3'-0" X 2'-6" ELEC BOX (3313T)

SUBMITTAL
SDGE 23-30 ELEC BOX (3313T)
SAN DIEGO GAS & ELECTRIC STANDARD PRODUCT

CUSTOMER			DRAWING SCALE (UNO)	
			1" = 1'-0"	
DATE DRAWN	JOB NUMBER	ITEM NUMBER	PRODUCTION QUANTITY	
09-28-18	SDGE			
DRAWN BY	ENGINEER	SALES	SALES ORDER	MANUFACTURED AT
CMJ	JER	TE		LAKE SIDE
DRAWING NUMBER			REVISION	SHEET
070-X013053-001			B	1 OF