

SITE SPECIFIC DATA					MINIMUM DEPTH	
Structure ID	-	Outlet Pipe Size	Ø6"	Minimum Rim to Outlet Depth	6.08'	
Treatment Flow Rate (gpm/cfs)	-	Ø8"			6.33'	
Peak Flow Rate (cfs)	-	Ø10"			6.58'	
Cartridge Quantity	-	Ø12"			6.83'	
Rim Elevation	-	Ø15"			7.08'	
		Ø18"			7.33'	

Pipe Data	Pipe Location	Pipe Size	Pipe Type	Invert Elevation
Inlet	-	-	-	-
Outlet	-	-	-	-

Notes:
-

PERFORMANCE SPECIFICATIONS	
Peak Treatment Capacities: ¹	
Max. Cartridge Quantity	3
NJDEP 80% Removal, 75 micron	102 gpm / 0.227 cfs
WA Ecology GULD - Basic & Phosphorus	51 gpm / 0.113 cfs
Max. Bypass Capacity	3.62 cfs

¹ Contact Oldcastle for alternative treatment and peak flow capacities.

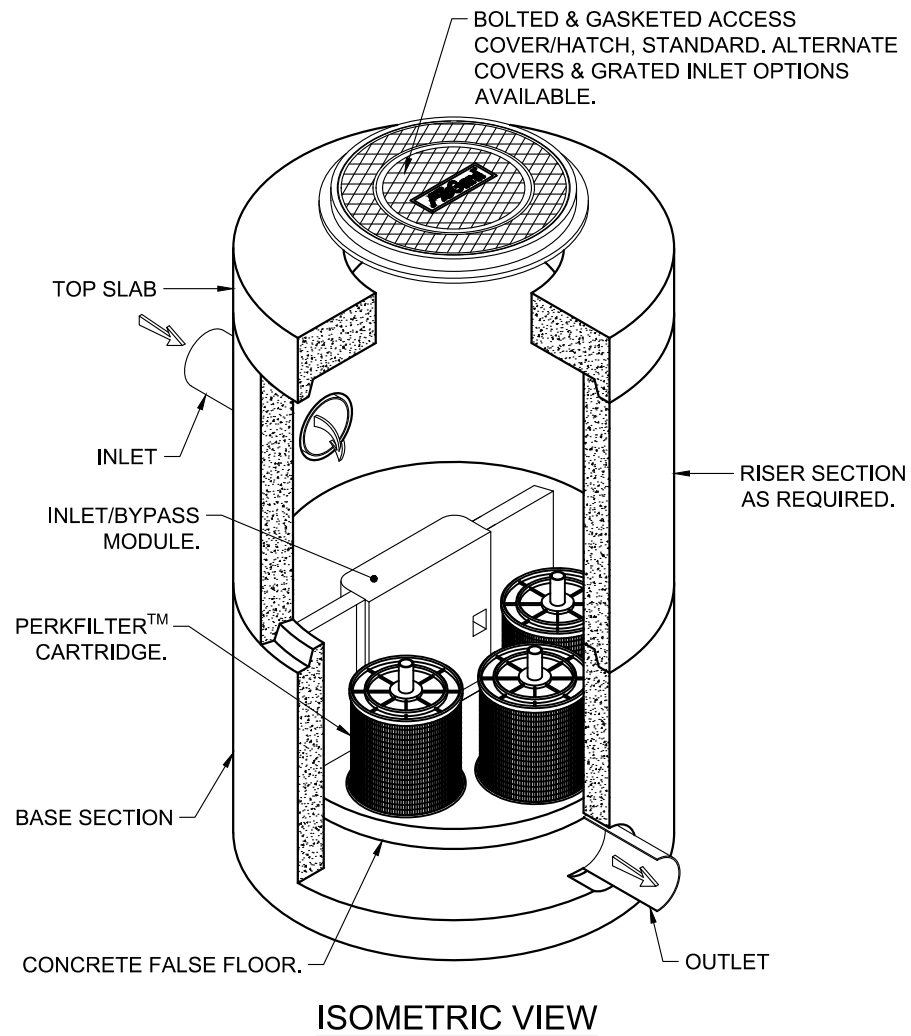
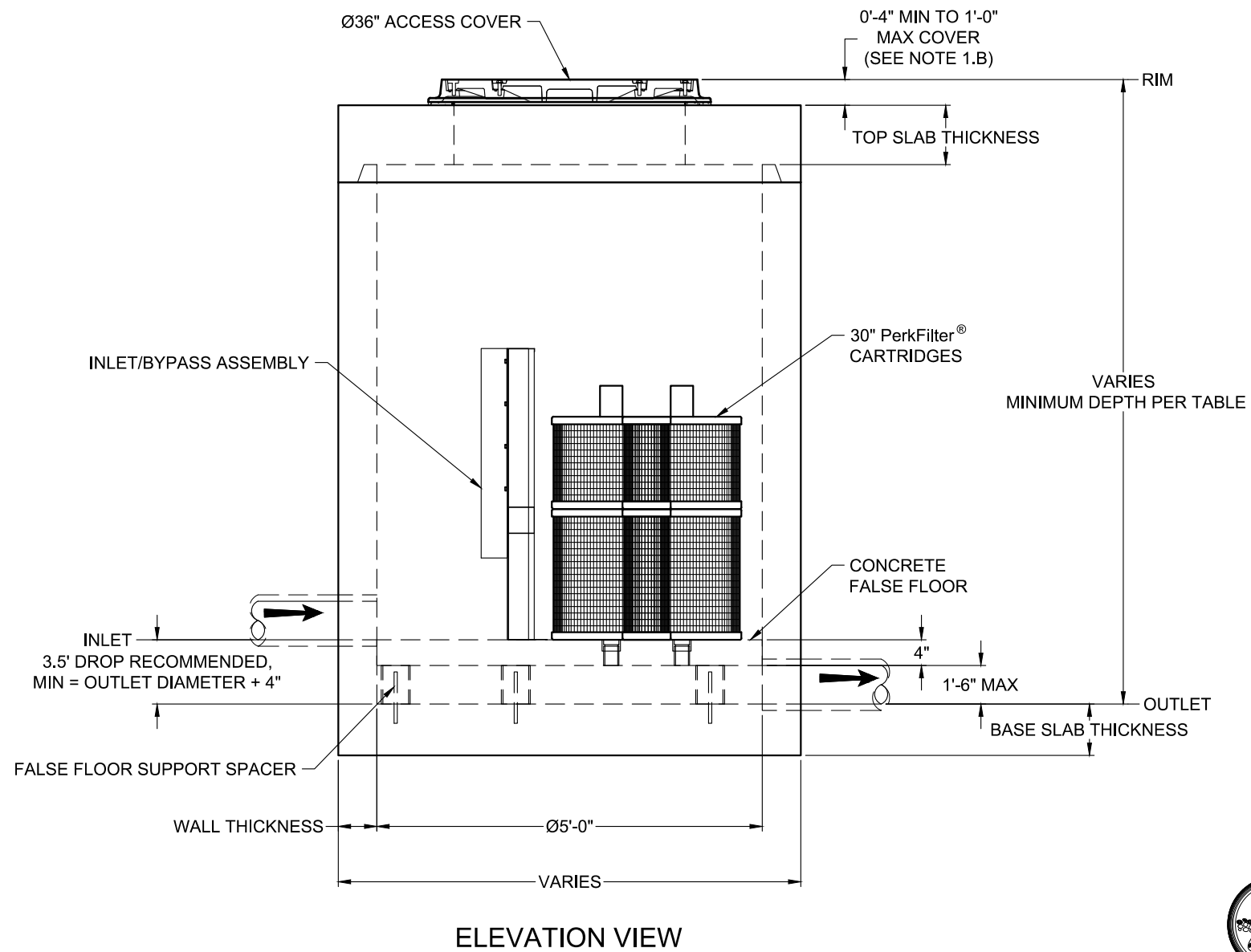
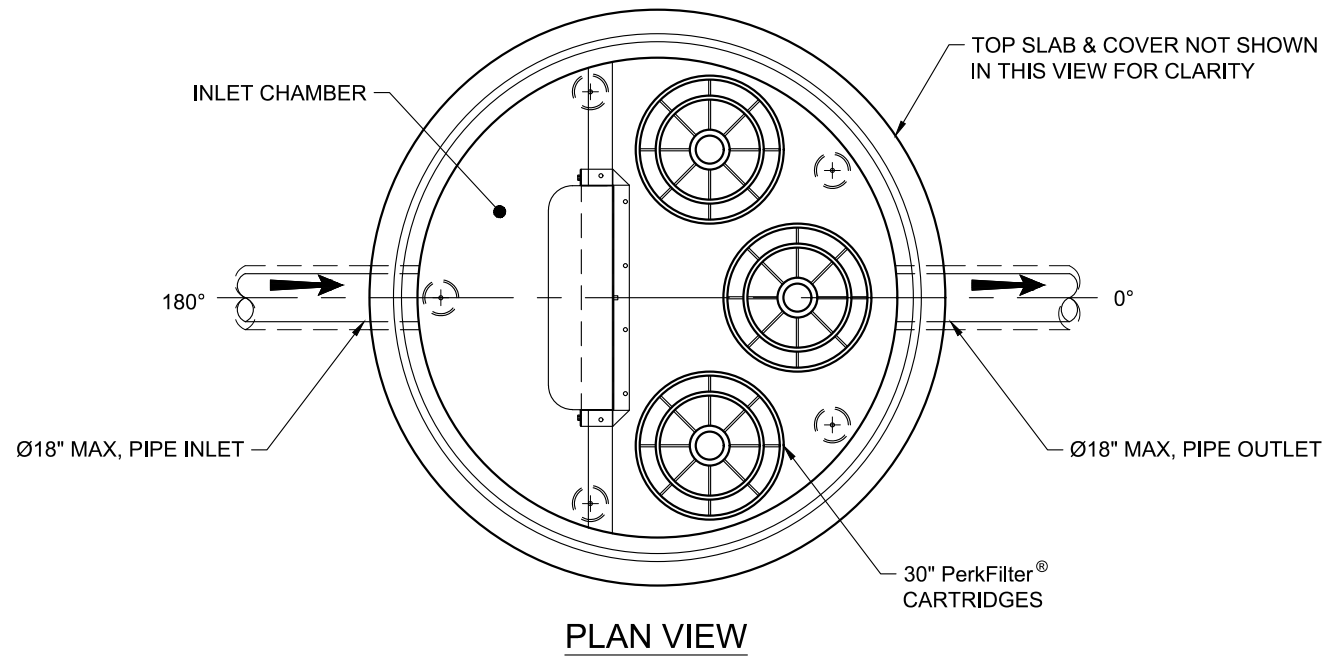

NOTES:

- DESIGN LOADINGS:
 - AASHTO HS-20-44 (WITH IMPACT)
 - DESIGN SOIL COVER: 1'-0" MAXIMUM
 - ASSUMED WATER TABLE: BELOW INVERT.
 - LATERAL EARTH PRESSURE: 45 PCF (DRAINED)
 - LATERAL LIVE LOAD SURCHARGE: 80 PSF (APPLIED TO 8'-0" BELOW GRADE)
 - NO LATERAL SURCHARGE FROM ADJACENT BUILDINGS, WALLS, PIERS, OR FOUNDATIONS.
- CONCRETE 28-DAY MINIMUM COMPRESSIVE STRENGTH: 5,000 PSI MINIMUM.
- REINFORCING: REBAR, ASTM A615/A706, GRADE 60
- CEMENT: ASTM C150
- REQUIRED ALLOWABLE SOIL BEARING CAPACITY: 2,500 PSF
- REFERENCE STANDARD:
 - ASTM C 478
 - ASTM C 497
- THIS STRUCTURE IS DESIGNED TO THE PARAMETERS NOTED HEREIN. ENGINEER-OF-RECORD SHALL VERIFY THAT NOTED PARAMETERS MEET OR EXCEED PROJECT REQUIREMENTS. IF DESIGN PARAMETERS ARE INCORRECT, REVIEWING ENGINEER/AUTHORITY SHALL NOTIFY OLDCASTLE INFRASTRUCTURE UPON REVIEW OF THIS SUBMITTAL.
- OVERSIZED HOLES TO ACCOMMODATE SPECIFIC PIPE TYPE MUST BE CONCENTRIC TO PIPE ID. AFTER PIPES ARE INSTALLED, ALL ANNULAR SPACES SHALL BE FILLED WITH A MINIMUM OF 3,000 PSI CONCRETE FOR FULL THICKNESS OF PRECAST WALLS. PIPES ARE TO BE FLUSH WITH THE INSIDE SURFACE OF THE CONCRETE STRUCTURE.
- CONTRACTOR RESPONSIBLE TO VERIFY ALL SIZES, LOCATIONS, AND ELEVATIONS OF OPENINGS.
- CONTRACTOR RESPONSIBLE TO ENSURE ADEQUATE BEARING SURFACE IS PROVIDED (I.E. COMPACTED AND LEVEL PER PROJECT SPECIFICATIONS).
- SECTION HEIGHTS, SLAB/WALL THICKNESSES, AND KEYWAYS ARE SUBJECT TO CHANGE AS REQUIRED FOR SITE REQUIREMENTS AND/OR DUE TO PRODUCT AVAILABILITY AND PRODUCTION FACILITY CONSTRAINTS.
- FOR SITE SPECIFIC DRAWINGS WITH DETAILED STRUCTURE DIMENSIONS AND WEIGHTS, PLEASE CONTACT OLDCASTLE INFRASTRUCTURE.
- MAXIMUM PICK WEIGHTS:
 - TOP SLAB: XX,XXX LBS
 - RISER: XX,XXX LBS
 - BASE: XX,XXX LBS* (* COMBINED WEIGHT OF BASE INCLUDES FALSE FLOOR, AND PRODUCT INTERNALS.)
- INTERNALS SHALL CONSIST OF CARTRIDGES, INLET/BYPASS ASSEMBLIES, FALSE FLOOR AND FALSE FLOOR SUPPORT SPACERS.



Ph: 800.579.8819 | www.oldcastleinfrastructure.com/stormwater
 THIS DOCUMENT IS THE PROPERTY OF OLDCASTLE INFRASTRUCTURE, INC. IT IS CONFIDENTIAL, SUBMITTED FOR REFERENCE PURPOSES ONLY AND SHALL NOT BE USED IN ANY WAY INJURIOUS TO THE INTERESTS OF, OR WITHOUT THE WRITTEN PERMISSION OF OLDCASTLE INFRASTRUCTURE, INC. COPYRIGHT © 2023 OLDCASTLE INFRASTRUCTURE, INC. ALL RIGHTS RESERVED.

PerkFilter® Manhole (STANDARD)
 Ø60" with 30" Cartridges

CUSTOMER	-	REVISION	-	SHEET	1 OF 1
PROJECT NAME	-	REV DATE	-		
SHEET NAME	Specifier Drawing				
	PFMH-60-30				

