

FLOOR PLAN

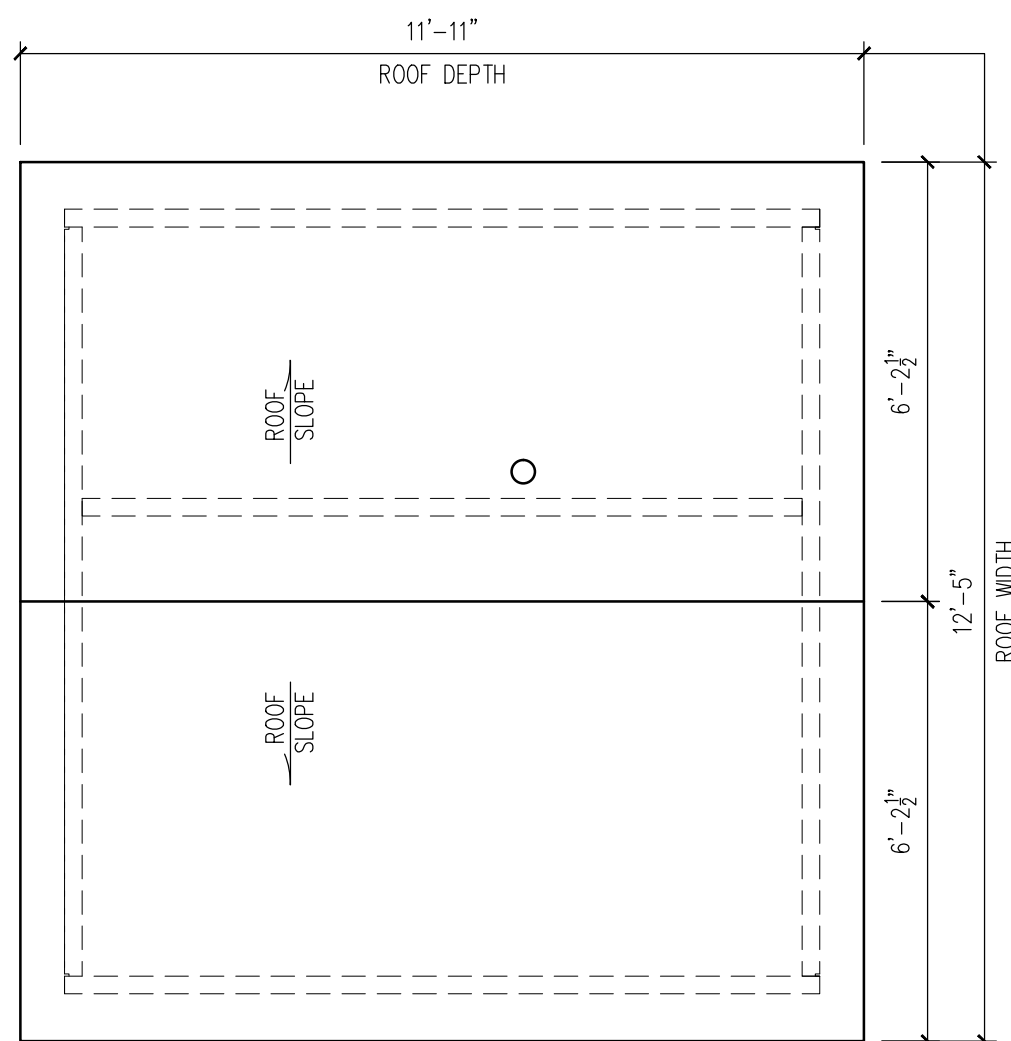

ROOF PLAN

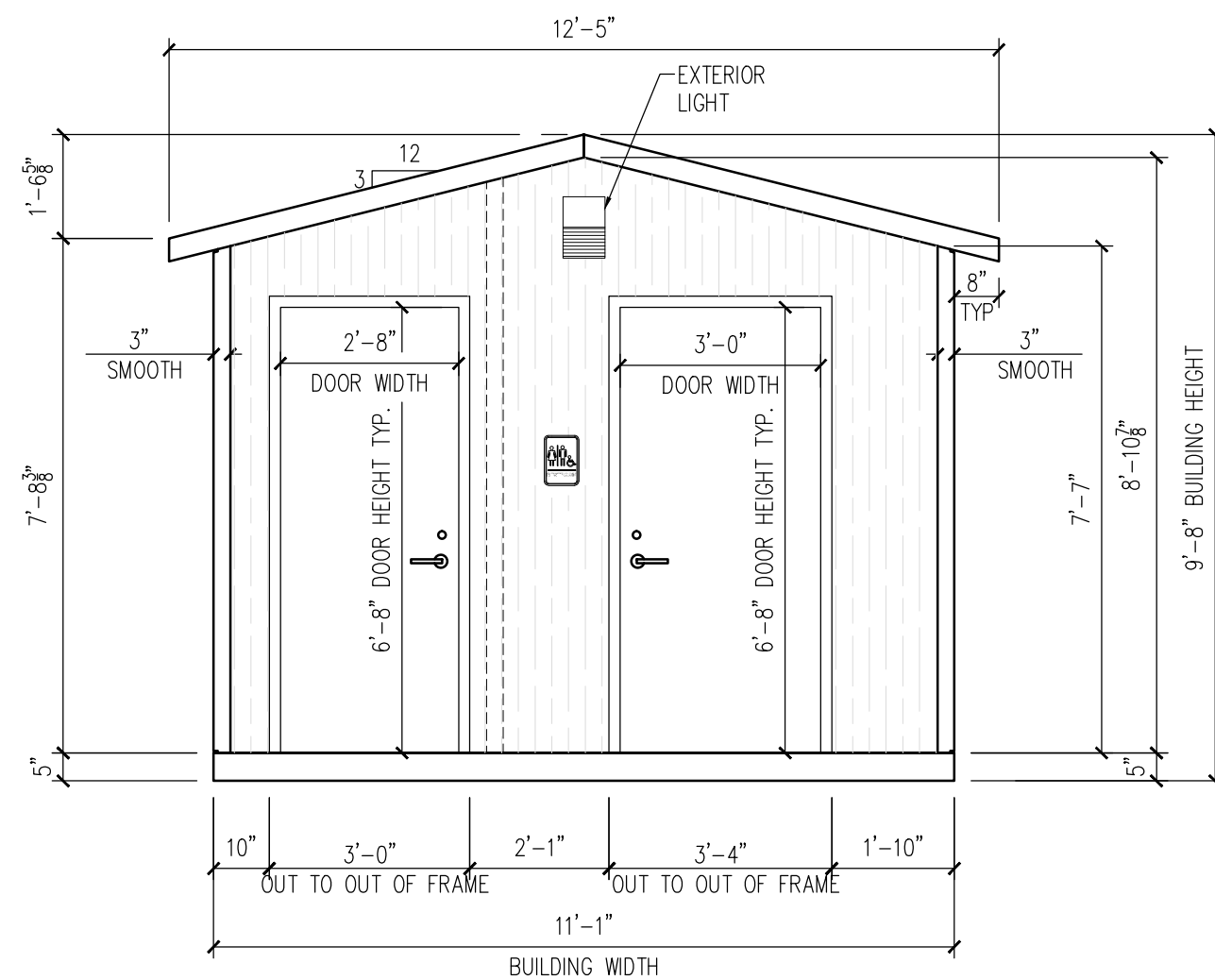

FRONT ELEVATION

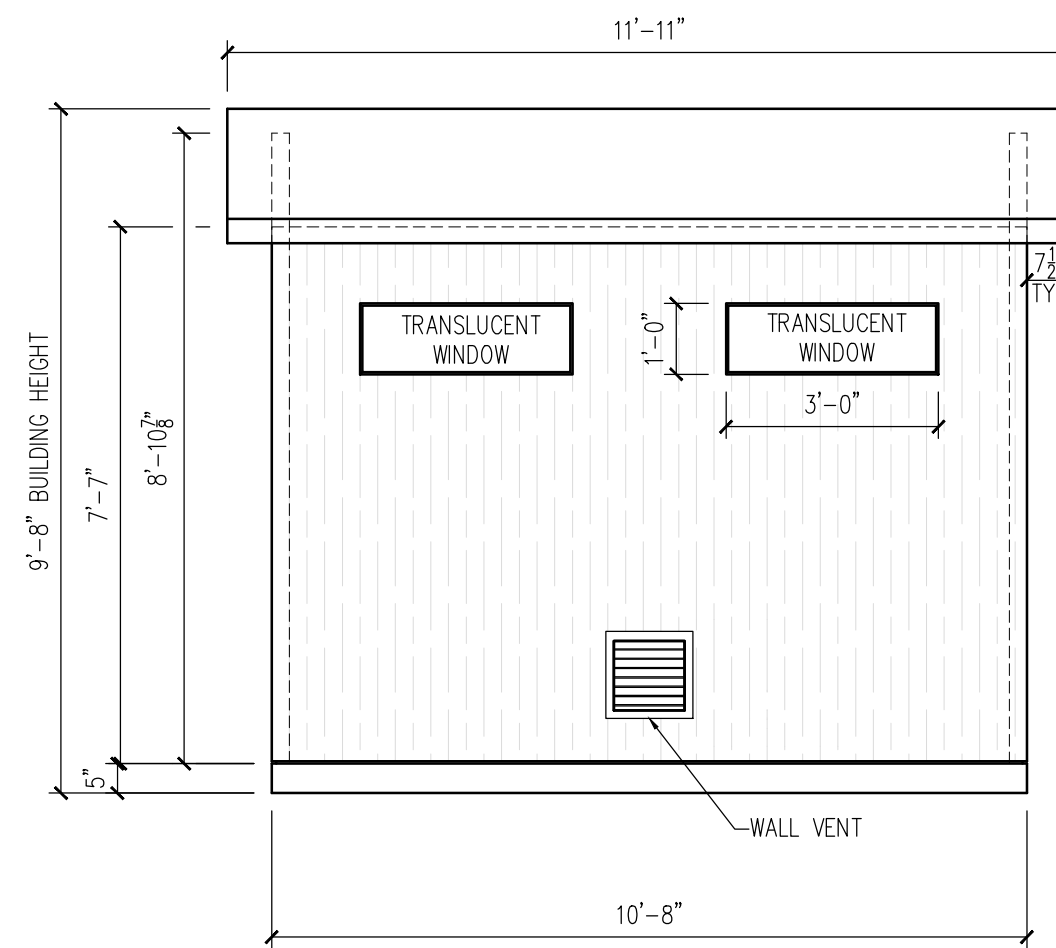

RIGHT ELEVATION

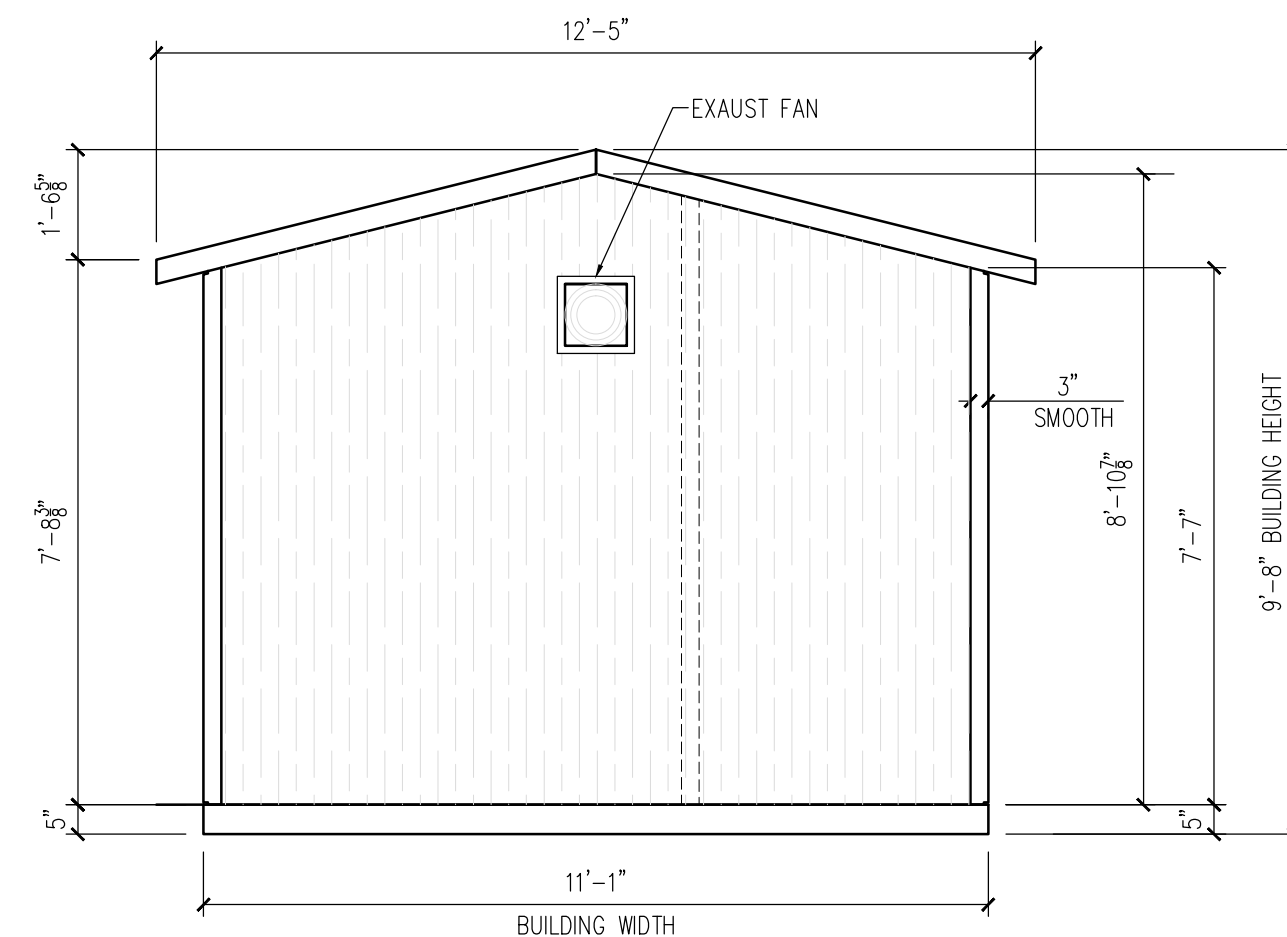

REAR ELEVATION

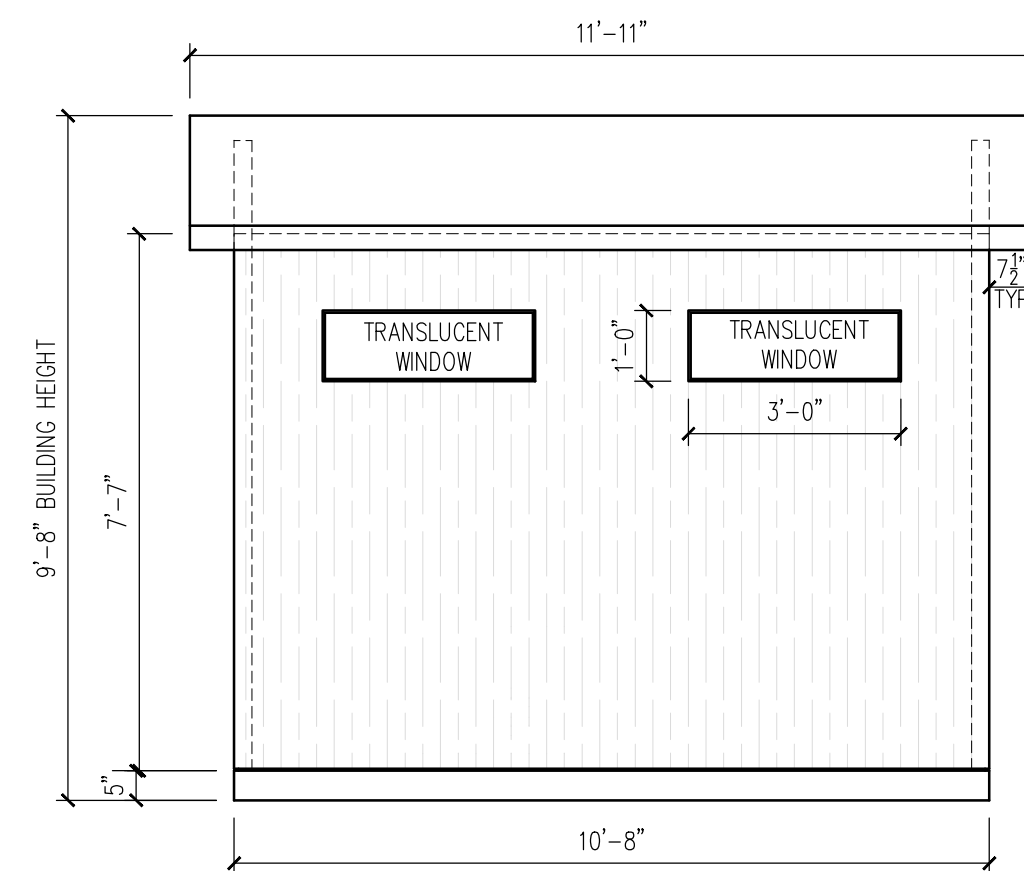

LEFT ELEVATION

NOTE: FINISH OPTIONAL, VARIOUS FINISHES ARE AVAILABLE

- EASI-BRICK
- BARNBOARD
- BROOM
- OTHER: \_\_\_\_\_

- GENERAL NOTES:
- ALL REQUIRED OPENINGS FOR ELECTRIC, MECHANICAL, LOUVERS, ETC. MUST BE SIZED AND LOCATED BY BUYER ON THIS DRAWING (OPENING SIZES AND LOCATIONS MAY HAVE TO BE ALTERED IF THEY INTERFERE WITH CONNECTIONS OR REINFORCING)
  - ALL VIEWS ARE FROM EXTERIOR
  - A SIGNED COPY MUST BE RETURNED BEFORE BUILDING CAN BE RELEASED FOR PRODUCTION

MESSAGE CENTER	
BUILDING FINISH	WALLS: _____
	ROOF: _____
BUILDING STAIN	_____
DOOR COLOR	_____
BUILDING WEIGHT	_____
CUSTOMER APPROVAL	
APPROVED BY:	DATE:

**EASI EASI-SET® WORLDWIDE**  
**SET®**  
 WORLDWIDE

REV	INI.	DESCRIPTION	DATE
1			
2			
3			
4			

PROJECT: 10'-8" x 11'-1" x 9'-8"  
 EASI-SET CONRAD FLUSH  
 SINGLE UNISEX RESTROOM  
 CONTRACTOR: \_\_\_\_\_

BUILDING LAYOUT
JOB #
DRAWN BY
CHECK BY
ISSUE DATE
SHEET LAYOUT

5119 Catlett Rd. • Midland, VA 22728 • info@EasiSet.com  
 www.EasiSet.com • 800-547-4045 • Fax 540-439-2541