

GENERAL DESIGN NOTES:

1. STRENGTH DESIGN METHOD IN ACCORDANCE WITH (I.A.W.) ACI 318.
2. APPLICABLE DESIGN DOCUMENTS (CURRENT EDITIONS):
 - ACI 318 BUILDING CODE REQUIREMENTS FOR STRUCTURAL CONCRETE (MAIN DESIGN SPECIFICATION).
 - ASTM C890 STANDARD PRACTICE FOR MINIMUM STRUCTURAL LOADING FOR MONOLITHIC OR SECTIONAL PRECAST CONCRETE WATER AND WASTEWATER STRUCTURES (LOADING SPECIFICATION).
 - ASTM C478 STANDARD SPECIFICATION FOR PRECAST MANHOLES (PRODUCT SPECIFICATION).
3. PRECAST RATED FOR HS20-44 TRUCK LIVE LOAD W/ IMPACT I.A.W. ASTM C890.
4. MAX DEPTH TO INVERT OF MANHOLE (I.E. FLOOR) = 30'.
5. LATERAL DESIGN PRESSURES (AS APPLICABLE TO DESIGN):
 - EQUIV DRY SOIL FLUID PRESSURE = 47 PCF.
 - EQUIV SATURATED SOIL FLUID PRESSURE = 85 PCF.
 - HYDROSTATIC WATER PRESSURE = 62.4 PCF.
 - LIVE LOAD SURCHARGE = 80 PSF
7. DESIGN CONCRETE COMPRESSIVE STRENGTH AT 28 DAYS = 4,000 PSI (MIN).
8. REINFORCEMENT:
 - CARBON-STEEL DEFORMED BARS: ASTM A615, $f_y = 60$ KSI (MIN).
 - WELDED WIRE REINFORCEMENT (PLAIN): ASTM A1064 $f_y = 65$ KSI (MIN).
 - WELDED WIRE REINFORCEMENT (DEFORMED): ASTM A1064 $f_y = 70$ KSI (MIN).
9. JOINT SEALANT (PER CONTRACT SPECIFICATIONS):
 - CS-102 CONSEAL BUTYL RUBBER SEALANT (OR EQUIV.) I.A.W. ASTM C990 FED. SPEC. SS-S-210.
 - CS-212 CONSEAL EXTERIOR JOINT WRAP (OR EQUIV.) I.A.W. ASTM C877 AND ASTM C990.
 - CS-50 CONSEAL LIQUID BUTYL PRIMER (OR EQUIV.) AS NEEDED.
10. COPOLYMER POLY PROPYLENE STEEL REINFORCED STEPS I.A.W. ASTM C478 SPACED 16" O.C.
11. OPENINGS CAST OR CORED IN MANHOLE TO DEFLECTIONS AND ELEVATIONS SPECIFIED ON CONTRACT DRAWINGS MAX HOLE SIZE IS 90" (72" RCP).
12. PRECAST INVERT PROVIDED UPON REQUEST: MIN $\frac{1}{4}$ " PER FT BENCH SLOPE FROM SPRINGLINE

GRADE RING

HEIGHT	WEIGHT (lbs)
4"	200
6"	300

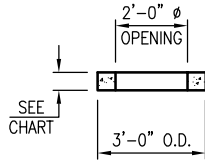

TRANSITION SLAB

WT = 11,800 LBS.

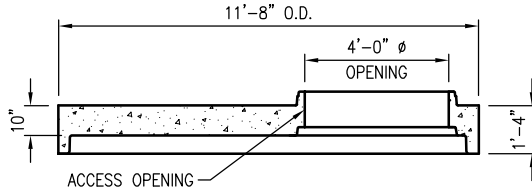

FLAT TOP

WT = 13,800 LBS.

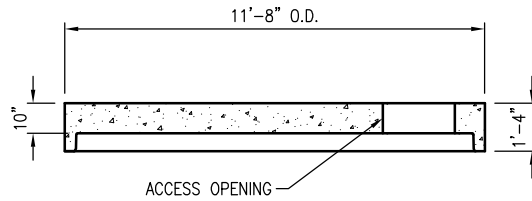

RISER SECTION

HEIGHT	WEIGHT (lbs)
2.67' RISER	11,300
3.00' RISER	12,800
3.50' RISER	14,900
4.00' RISER	17,000
5.00' RISER	21,300
6.00' RISER	25,500
6.67' RISER	28,500

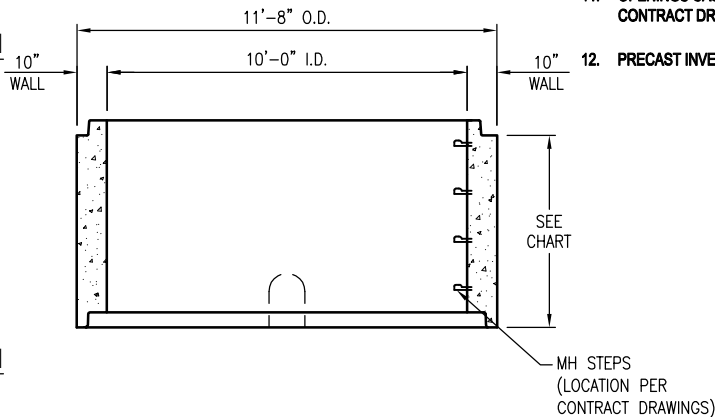

DOGHOUSE RISER SECTION

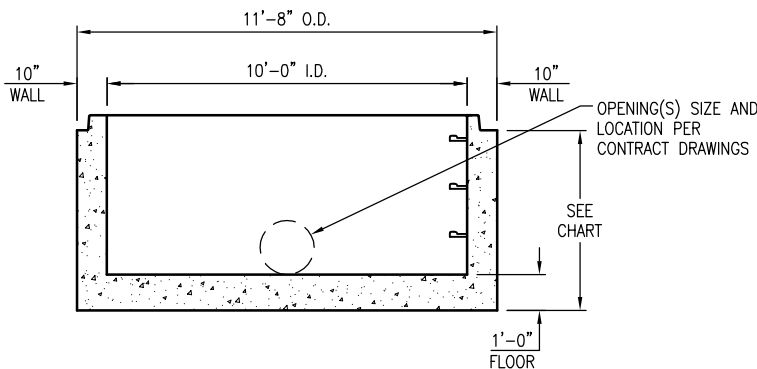

STANDARD BASE SECTION

HEIGHT	WEIGHT (lbs)
2.67' BASE	22,830
3.00' BASE	24,350
3.50' BASE	26,375
4.00' BASE	28,500
5.00' BASE	32,750

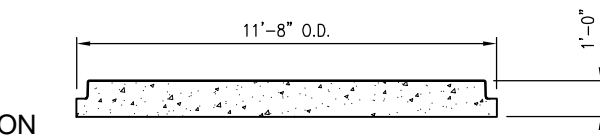

STANDARD BASE SLAB SECTION

WT = 15,250 LBS.

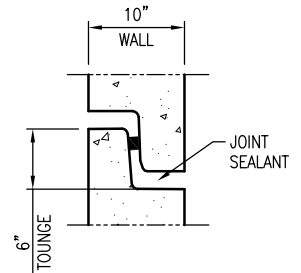

JOINT DETAIL
SCALE: 1/4" = 1'-0"

SCALE (TYP): 3/16" = 1'-0"



THIS DOCUMENT IS THE PROPERTY OF OLDCASTLE PRECAST, INC. IT IS CONFIDENTIAL, SUBMITTED FOR REFERENCE PURPOSES ONLY, AND SHALL NOT BE USED IN ANY WAY INJURIOUS TO THE INTERESTS OF, OR WITHOUT THE WRITTEN PERMISSION OF OLDCASTLE PRECAST, INC. COPYRIGHT © 2017 OLDCASTLE PRECAST, INC. ALL RIGHTS RESERVED

10' DIAMETER MANHOLE SUBMITTAL LAYOUT

CUSTOMER					
DATE	SALES	DRAWN	ENGINEER	CHECKED	SALES ORDER
6/15/17		PPS			
DRAWING NUMBER				REVISION	SHEET
10-MH-2017					1 OF 1
				REV DATE	