

GENERAL DESIGN NOTES:

1. STRENGTH DESIGN METHOD IN ACCORDANCE WITH (I.A.W.)ACI 318.
2. CONCRETE COMPRESSIVE STRENGTH AT 28 DAYS = 5,000 PSI (MIN).
3. PRECAST RATED FOR HS20 LIVE LOAD W/ IMPACT I.A.W. AASHTO SPECIFICATION
4. DESIGN FILL RANGE = 0'(MIN) TO 2'(MAX)
5. GROUND WATER TABLE ASSUMED 3'-6" BELOW GRADE. IF DESIGN (OR ACTUAL) WATER TABLE IS LESS THAN ASSUMED, REVIEWING ENGINEER TO NOTIFY OLDCASTLE PRECAST UPON REVIEW OF THIS SUBMITTAL.
6. REINFORCEMENT:
 - CARBON-STEEL DEFORMED BARS: ASTM A615, fy = 60KSI (MIN).
7. JOINT SEALANT (AS DETAILED AND NOTED IN DRAWINGS HEREIN):
 - CS-102 CONSEAL BUTYL RUBBER SEALANT (OR EQUIV.) I.A.W. ASTM C990 FED. SPEC. SS-S-210.
8. PRECAST DESIGN DOES NOT INCLUDE ANY LATERAL OR SURCHARGE LOADS FROM OTHER BUILDINGS OR FOUNDATIONS ADJACENT TO THIS STRUCTURE. THIS STRUCTURE SHALL BE KEPT A MINIMUM OF 1:1 RATIO AWAY FROM OTHER FOOTINGS OR FOUNDATIONS.

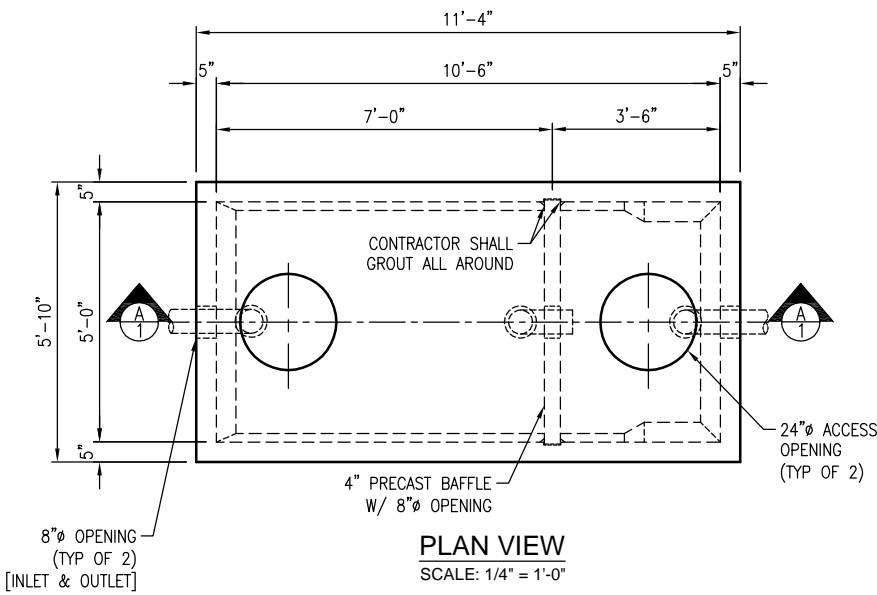

NOTES TO CONTRACTOR:

1. PLEASE VERIFY ALL SIZES, LOCATIONS, AND ELEVATIONS OF OPENINGS.
2. THE CONTRACTOR SHALL BE RESPONSIBLE FOR PROPER COORDINATION TO ENSURE THAT AN ADEQUATE BEARING SURFACE IS PROVIDED (I.E. LEVEL AND COMPACTED) PER PROJECT SPECIFICATIONS AND DRAWINGS.
3. AFTER PIPES ARE INSTALLED IN BLOCKOUTS, ALL ANNULAR SPACES SHALL BE FILLED WITH A MIN. OF 3,000 psi CONCRETE, TIGHT TO THE UNDERSIDE OF UPPER SECTION FOR FULL THICKNESS OF VAULT.
4. CONTRACTOR TO RESPONSIBLE FOR THE FOLLOWING:
 - SUPPLY & INSTALL ALL PIPING & SAMPLING TEES, GROUT IN BAFFLE ON BOTH SIDES,
 - GRAY WATER ONLY, BLACK WATER SHALL BE CARRIED BY SEPARATE SIDE SEWER,
 - FILL WITH CLEAN WATER PRIOR TO "START-UP" OF SYSTEM.

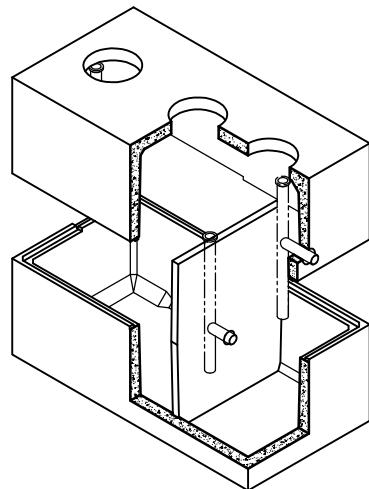
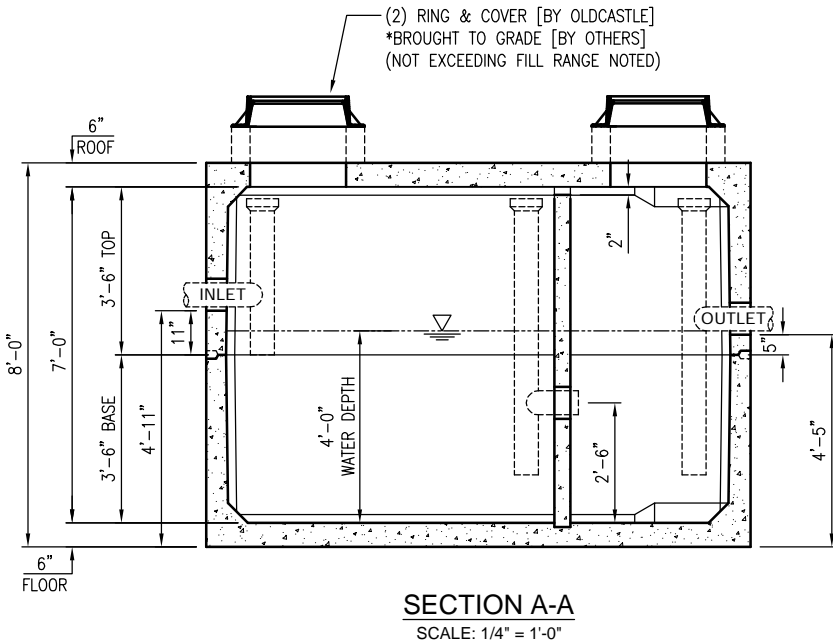

APPROX. WEIGHTS		
SECTION	WEIGHT (lbs)	Concrete(CY)
42" TOP	13,500	3.33
42" BASE	13,968	3.44
BAFFLE	1,700	0.42



THIS DOCUMENT IS THE PROPERTY OF OLDCASTLE PRECAST, INC. IT IS CONFIDENTIAL, SUBMITTED FOR REFERENCE PURPOSES ONLY, AND SHALL NOT BE USED IN ANY WAY INJURIOUS TO THE INTERESTS OF, OR WITHOUT THE WRITTEN PERMISSION OF OLDCASTLE PRECAST, INC. COPYRIGHT ©2017 OLDCASTLE PRECAST, INC ALL RIGHTS RESERVED

1,500 GALLON GREASE INTERCEPTOR
SUBMITTAL
5' X 10'-6" X 7' ID VAULT

CUSTOMER					
DATE	SALES	DRAWN	ENGINEER	CHECKED	SALES ORDER
10/13/17		LD			
DRAWING NUMBER				REVISION	SHEET
				REV DATE	1 OF 1

REVISIONS

REVISION	DATE	BY	SHEET	DESCRIPTION OF REVISION	REQUESTED BY
A					
B					

