

SPLIT CULVERTS

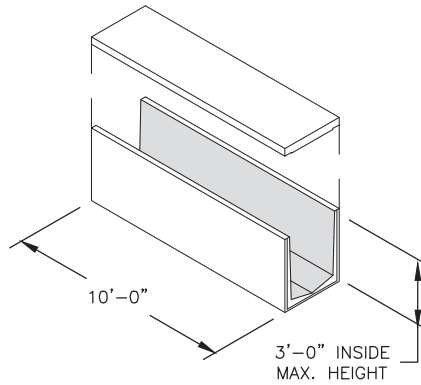

Split Culvert 2636

2'-0" Wide
Top Weight = 1,500 lbs.
Base Weight = 3,790 lbs.

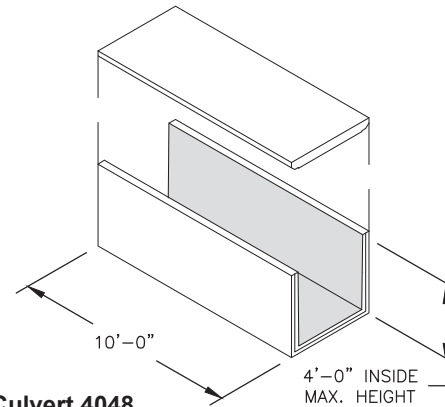

Split Culvert 4048

3'-0" Wide
Top Weight = 3,000 lbs.
Base Weight = 5,600 lbs.

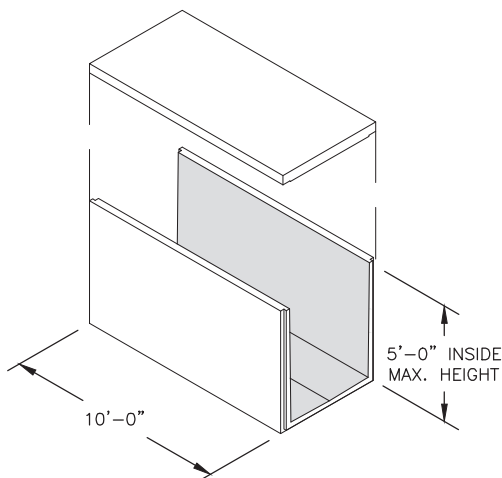

Split Culvert 4860

4'-0" Wide
Top Weight = 3,200 lbs.
Base Weight = 8,300 lbs.

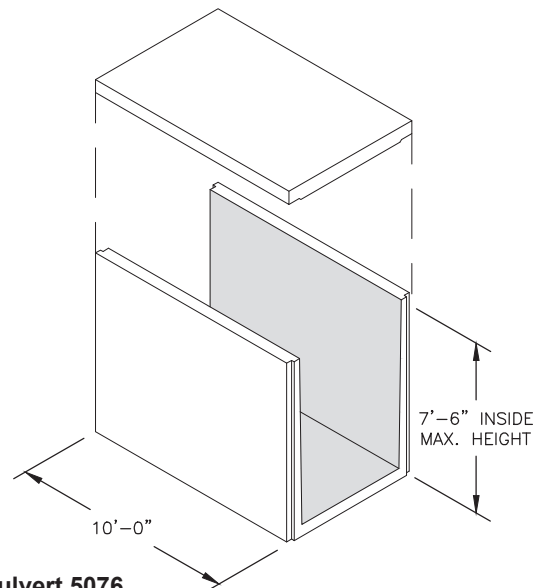

Split Culvert 5076

5'-0" Wide
Top Weight = 6,200 lbs.
Base Weight = 18,500 lbs.

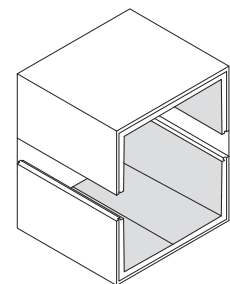

2 Base Option
Available On All Split Culverts

**Maximum Inside Height As Shown
Can Be Made To Any Height Shorter Than Maximum
Designed For HS-20 Wheel Loads**

Items Shown Are Subject To Change Without Notice
Issue Date: April 2016