

NetTech™

Easy Installation

Custom Sizing

Safe Handling

Reusable Design

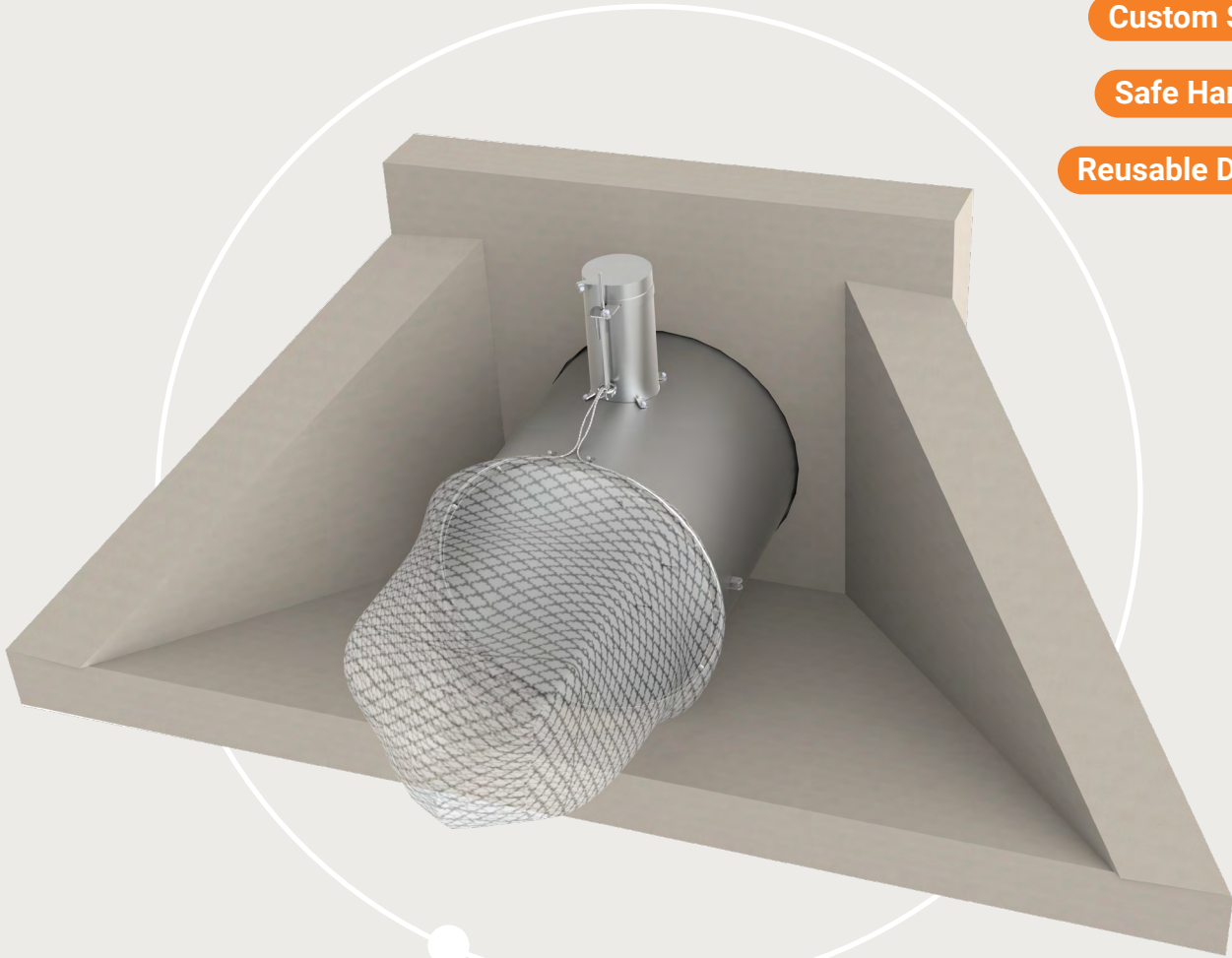

Innovative Pollutant Protection

NetTech™ gross pollutant trap (GPT) systems combine a marine-grade, stainless-steel pipe extension with a heavy-duty, UV stabilized polyethylene net. Systems can be customized to suit specific application sizes and flow rates for various stormwater outlets, outfalls and channels.

Revolutionary protection. Environmental solution.

The NetTech™ system is engineered to handle pollutants as safely and efficiently as possible. When water passes through the system, debris and other pollutants are held in the net as the rest of the water drains without flow interruptions. This prevents potential odors, infections or mosquito breeding from becoming an issue. The pipe extensions used allow the net to release in the event that it becomes fouled with intercepted debris. The net automatically detaches and chokes off on a short tether, allowing water to flow through the pipe normally. After the debris has been disposed and the net has been cleaned, the net can be reattached to the unit and resume pollutant capture.

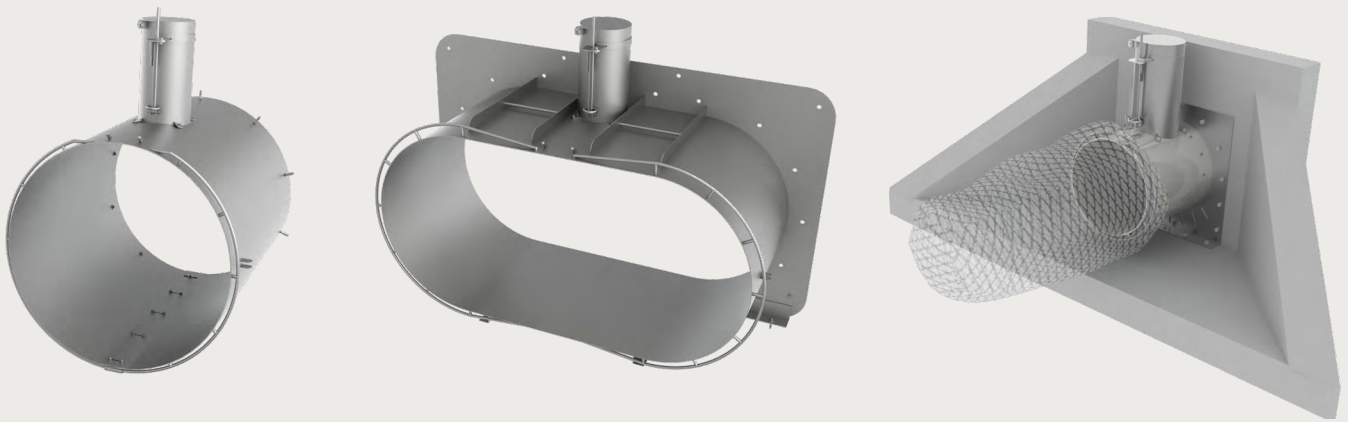

Available in round or ellipse shape, internal or flange mount, or customized to fit your needs.



4-A-089 Revision 4/2023

Trusted partnerships.
Full scale solutions.



www.oldcastleinfrastructure.com | (888) 965-3227