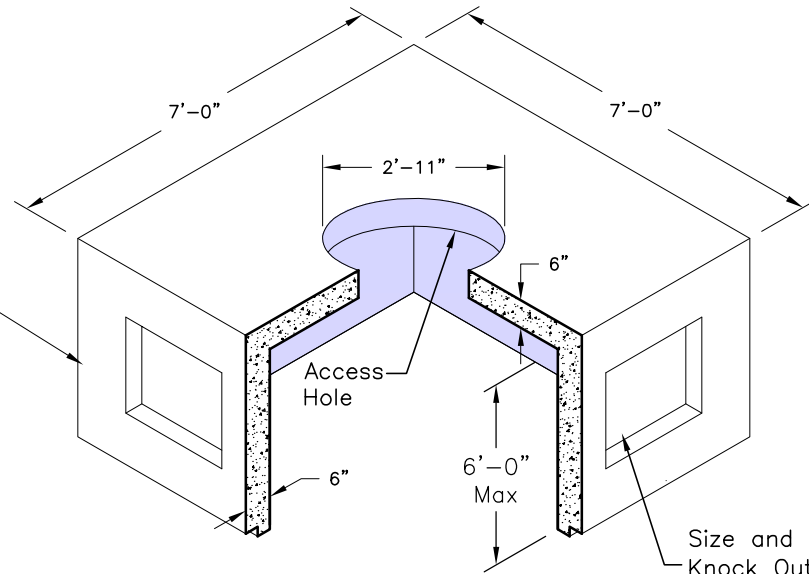

**TOP SECTION**
**7272-T**

Weight— See Table

TOP SECTION	
A	Weight
36"	9,025 Lbs.
48"	10,975 Lbs.
60"	12,925 Lbs.
72"	14,875 Lbs.

**BOTTOM SECTION**
**7272-B**

Weight— See Table

BOTTOM SECTION	
A	Weight
36"	9,525 Lbs.
48"	11,475 Lbs.
60"	13,425 Lbs.
72"	15,375 Lbs.

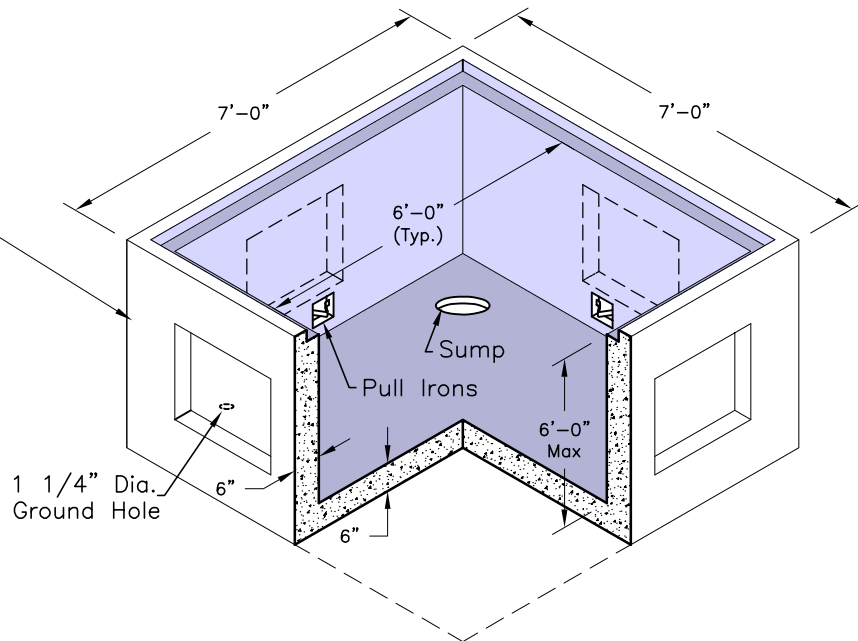
**SPECIFICATIONS:**

1. Concrete: Design Strength of 5500 PSI at 28 Days.
2. Steel Reinforcement: ASTM A-615 Grade 60.
3. Loading: Designed for HS-20 Loading.
4. C.I. Castings: ASTM A-48 Class 30/35.

**GENERAL NOTES:**

1. Different Height Sections are Available on Request.
2. All Weights Calculated with Solid Walls.
3. Access Manhole Location & Opening Size may vary.