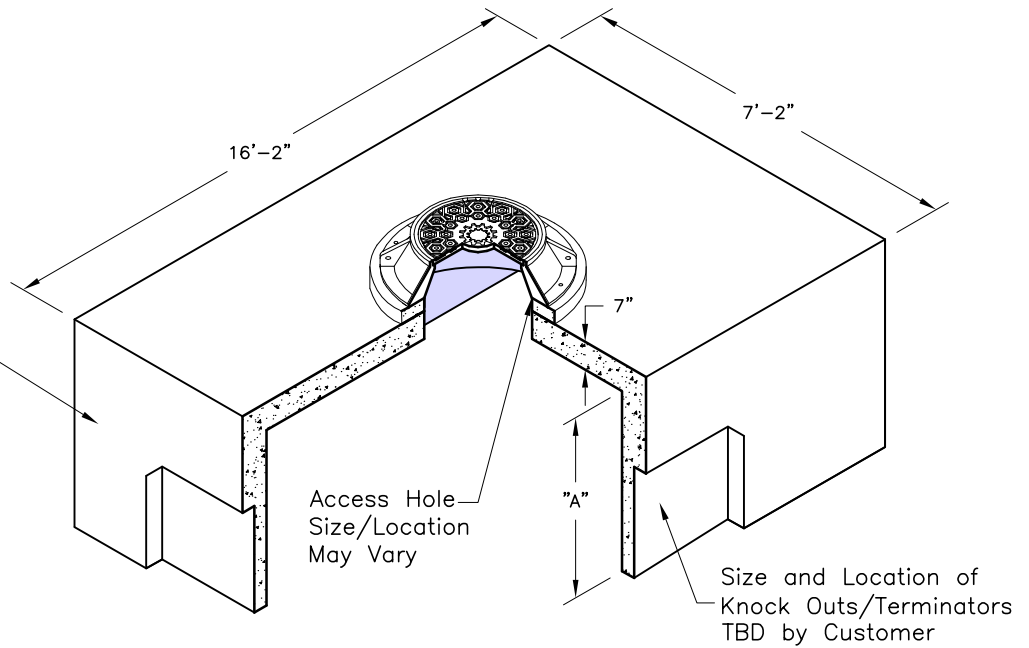

TOP SECTION
615 CV-T

Weight- See Table

TOP SECTION	
A	Weight
2'-0"	17,900 Lbs.
3'-6"	23,715 Lbs.

EXTENSION (Not Shown)
615 CV-E

Weight- See Table

EXTENSION	
HT.	Weight
2'-6"	14,170 Lbs.
3'-0"	17,000 Lbs.
5'-0"	28,335 Lbs.

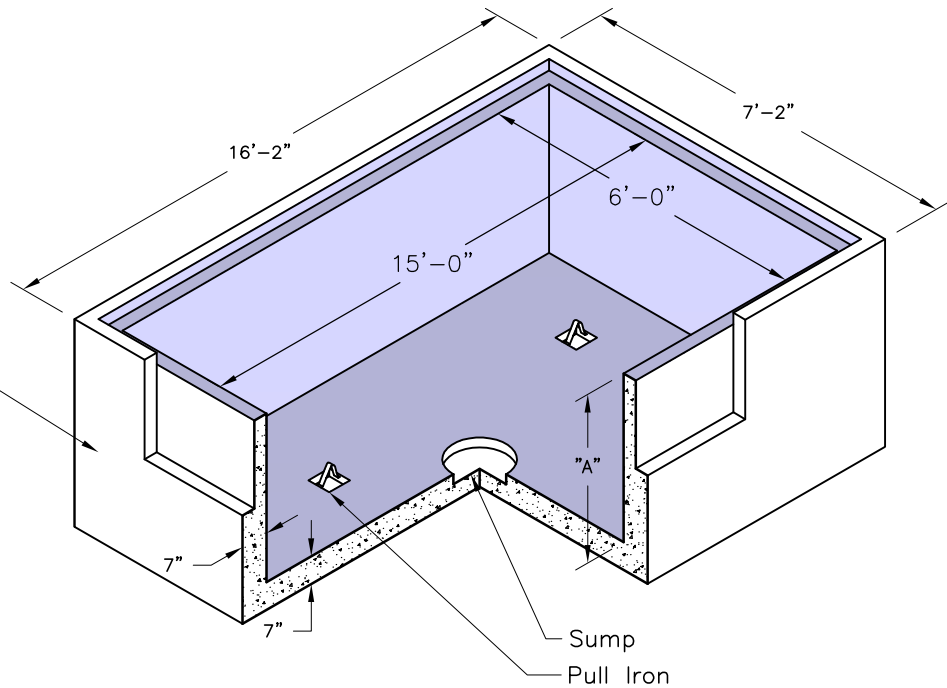
BOTTOM SECTION
615 CV-B

Weight- See Table

BOTTOM SECTION	
A	Weight
2'-0"	17,900 Lbs.
3'-6"	23,715 Lbs.

SPECIFICATIONS:

1. Concrete: Design Strength of 5500 PSI at 28 Days.
2. Steel Reinforcement: ASTM A-615 Grade 60.
3. Loading: Designed for HS-20 Loading.
4. C.I. Castings: ASTM A-48 Class 30/35.

GENERAL NOTES:

1. Different Height Sections are Available on Request.
2. All Weights Calculated with Solid Walls.
3. Manhole Location & Opening Size may vary.