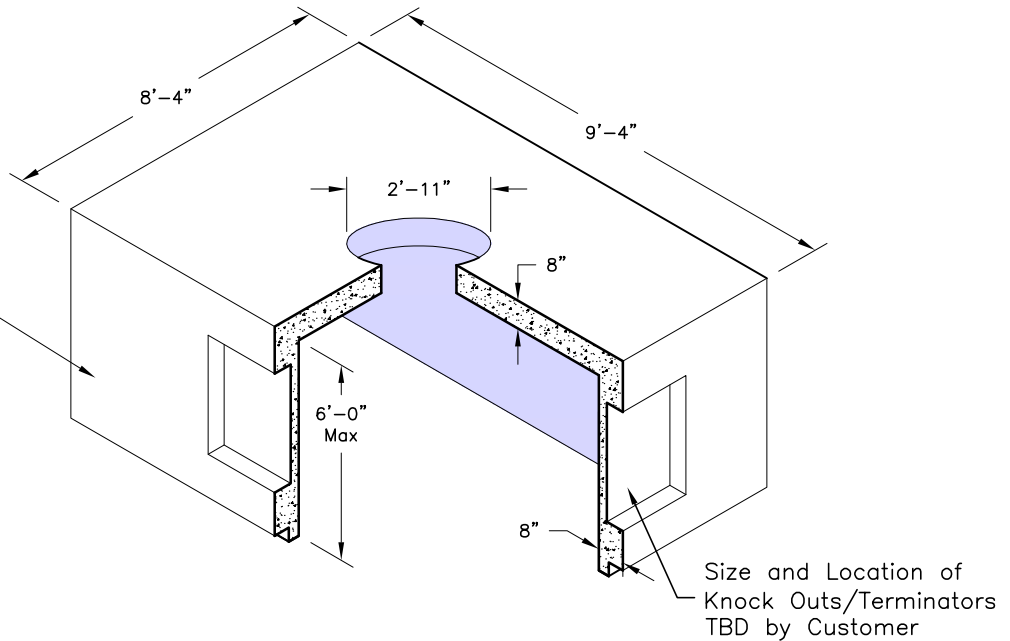

TOP SECTION
8496-T

Weight- See Table

TOP SECTION	
A	Weight
36"	16,910 Lbs.
48"	20,180 Lbs.
60"	23,445 Lbs.
72"	26,710 Lbs.

BOTTOM SECTION
8496-B

Weight- See Table

BOTTOM SECTION	
A	Weight
36"	17,580 Lbs.
48"	20,845 Lbs.
60"	24,115 Lbs.
72"	27,380 Lbs.

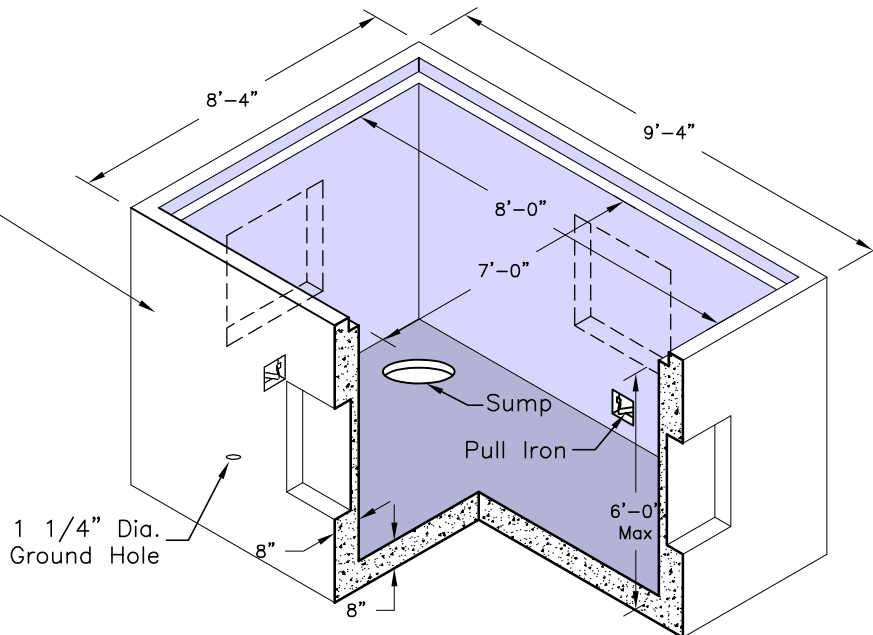
SPECIFICATIONS:

1. Concrete: Design Strength of 5500 PSI at 28 Days.
2. Steel Reinforcement: ASTM A-615 Grade 60.
3. Loading: Designed for HS-20 Loading.
4. C.I. Castings: ASTM A-48 Class 30/35.

GENERAL NOTES:

1. Different Height Sections are Available on Request.
2. All Weights Calculated with Solid Walls.
3. Access Manhole Location & Opening Size may vary.
4. Knock Out/Termaducts Location & Size may vary.