

TOP SLAB

THICKNESS	WEIGHT (lbs)
6"	2,790
8"	3,690

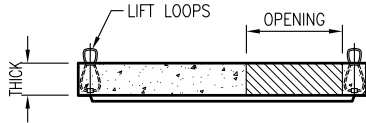

RETURN TOP

HEIGHT	WEIGHT (lbs)
1.5'	4,440
2.5'	6,090
3.5'	7,740
4.5'	9,390
5.5'	11,040

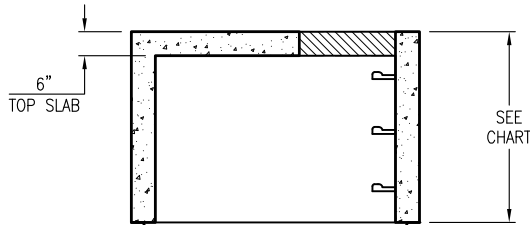

RISER SECTION

HEIGHT	WEIGHT (lbs)
1.33'	2,183
2.67'	4,383
4.00'	6,583
5.00'	8,233
6.00'	9,883

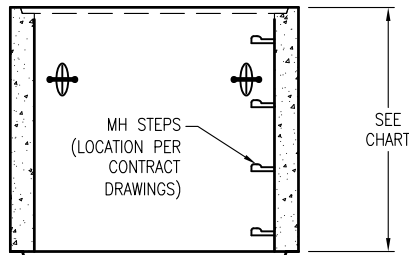

WAFFLE BOX

HEIGHT	WEIGHT (lbs)
3.5'	6,058
4.5'	6,996
5.5'	7,933
6.5'	8,871

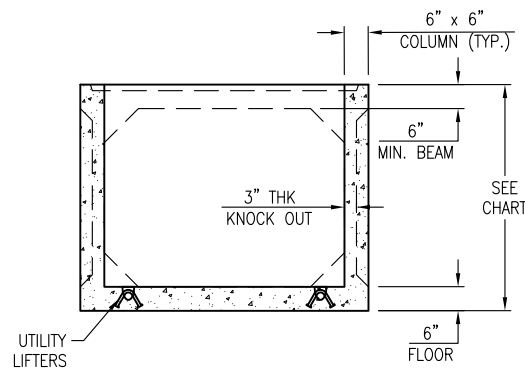

SOLID BOX

HEIGHT	WEIGHT (lbs)
3.5'	7,543
4.5'	9,193
5.5'	10,843
6.5'	12,493

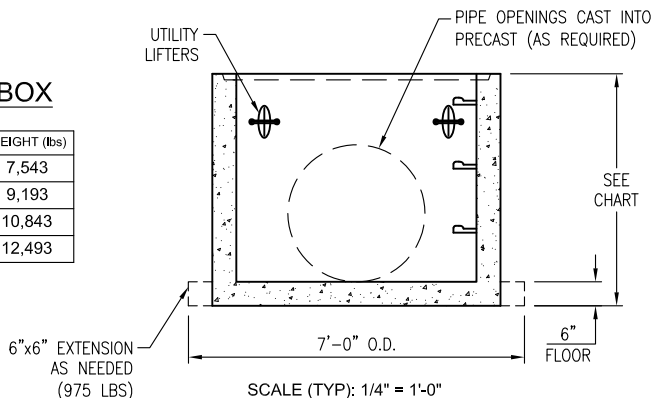

GENERAL DESIGN NOTES:

- STRENGTH DESIGN METHOD IN ACCORDANCE WITH (I.A.W.) ACI 318.
- APPLICABLE DESIGN DOCUMENTS (CURRENT EDITIONS):
 - NCDOT STANDARD DRAWING # 840.45 (WAFFLE/NON - TRAFFIC RATED) OR # 840.46(SOLID / TRAFFIC RATED).
 - ACI 318 BUILDING CODE REQUIREMENTS FOR STRUCTURAL CONCRETE (MAIN DESIGN SPECIFICATION).
 - ASTM C890 STANDARD PRACTICE FOR MINIMUM STRUCTURAL LOADING FOR MONOLITHIC OR SECTIONAL PRECAST CONCRETE WATER AND WASTEWATER STRUCTURES (LOADING SPECIFICATION).
 - ASTM C913 STANDARD SPECIFICATION FOR PRECAST CONCRETE & WATER & WASTEWATER STRUCTURES.
- MAX DEPTH TO INVERT OF PRECAST (I.E. FLOOR) = 15' FOR SOLID BASE & 10' FOR WAFFLE BASE.
- GWT ASSUMED BELOW INVERT OF PRECAST.
- LATERAL DESIGN PRESSURES (AS APPLICABLE TO DESIGN):
 - EQUIV DRY SOIL FLUID PRESSURE = 47 PCF.
 - EQUIV SATURATED SOIL FLUID PRESSURE = 85 PCF.
 - LIVE LOAD SURCHARGE = 80 PSF.
- DESIGN CONCRETE COMPRESSIVE STRENGTH AT 28 DAYS = 4,000 PSI (MIN).
- REINFORCEMENT:
 - CARBON-STEEL DEFORMED BARS: ASTM A615, fy = 60KSI (MIN).
 - WELDED WIRE REINFORCEMENT (DEFORMED): ASTM A1064 fy = 70 KSI (MIN).
- COPOLYMER POLY PROPYLENE STEEL REINFORCED STEPS I.A.W ASTM C478 SPACED 16" O.C.
- PRECAST BASE AND RISER SECTIONS MAY BE USED FOR THE FOLLOWING DOT STANDARDS AS NOTED ON NCDOT STANDARD DRAWING:
 - WAFFLE BOX (NCDOT#840.45): 840.01, 840.20, 8940.04, 840.05, 840.11, 840.12, 840.14, 840.15, 840.17, 840.18, 840.19, 840.26, 840.27, 840.28, 840.28, 840.31, 840.32 & 840.41.
 - SOLID BOX (NCDOT #840.46): 840.04, 840.05, 840.14, 840.31, 840.32, 840.34, 840.35, 840.36, & 840.41.
 - MIN 4" BEAM FOR OPENINGS IN WALL & 6" BEAM FOR CORNER HOLES PER NC DOT.
- LIFT LOOPS, PINS OR UTILITY ANCHORS PROVIDED FOR HANDLING. CONTRACTOR SHALL BE RESPONSIBLE FOR FOLLOWING OLDCASTLE PRECAST, INC. LIFTING INSTRUCTIONS AS SHOWN ON BACK OF SHIPPING TICKET.



****THIS MUST BE FILLED OUT BEFORE MANUFACTURING BEGINS****

APPROVED W/ NO EXCEPTIONS TAKEN:

APPROVED AS NOTED:

REVISED AND RESUBMIT:

SIGNATURE _____ DATE _____

1431 PRODUCT RD, FLOUQUAY VARINA, NC
OFFICE 919-552-2252, FAX 844-866-7476

NC ENGINEERING LICENSE #F-1002

THIS DOCUMENT IS THE PROPERTY OF OLDCASTLE PRECAST, INC. IT IS CONFIDENTIAL, SUBMITTED FOR REFERENCE PURPOSES ONLY, AND SHALL NOT BE USED IN ANY WAY INJURIOUS TO THE INTERESTS OF, OR WITHOUT THE WRITTEN PERMISSION OF OLDCASTLE PRECAST, INC. COPYRIGHT © 2017 OLDCASTLE PRECAST, INC ALL RIGHTS RESERVED

60"x60" DRAINAGE BOX
SUBMITTAL LAYOUT

CUSTOMER					
DATE	SALES	DRAWN	ENGINEER	CHECKED	SALES ORDER
07/31/17		PPS			
DRAWING NUMBER				REVISION	SHEET
5x5 DRAINAGE BOXES				REV DATE	1 OF 1