

**PLAN VIEW**  
SCALE: 1/4" = 1'-0"

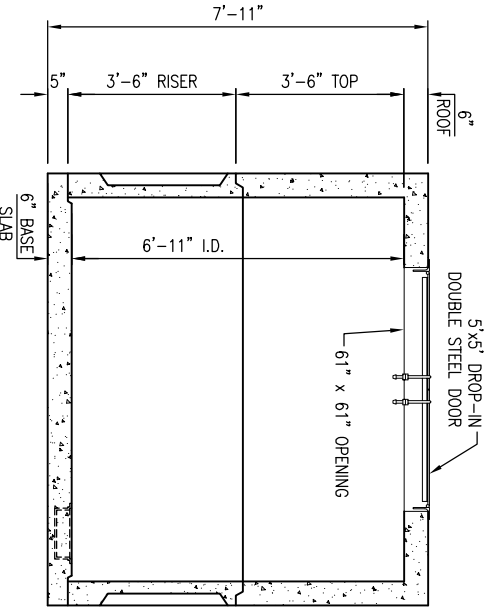

**SECTION A-A**

SCALE: 1/4" = 1'-0"

- INFORMATION NEEDED:**
1. TOP OF SEPARATOR ELEVATION \_\_\_\_\_
  2. INLET PIPE SIZE \_\_\_\_\_
  3. INLET PIPE ELEVATION \_\_\_\_\_
  4. OUTLET PIPE SIZE \_\_\_\_\_
  5. OUTLET PIPE ELEVATION \_\_\_\_\_

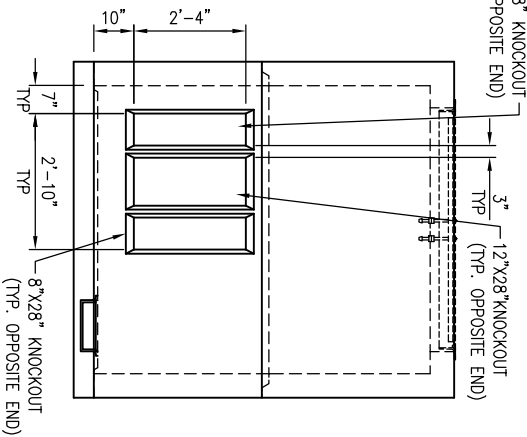

**VIEW B**

SCALE: 1/4" = 1'-0"

**GENERAL DESIGN NOTES:**

1. STRENGTH DESIGN METHOD I.A.W. ACI 318
2. APPLICABLE DESIGN CODES:
  - ACI 318 (MAIN DESIGN SPECIFICATION)
  - ASTM C913 (PRODUCT SPECIFICATION)
3. PRECAST RATED FOR HS20 LIVE LOAD W/ IMPACT I.A.W. AASHTO SPECIFICATION
4. DESIGN FILL RANGE = 0'(MIN) TO 2'(MAX)
5. GROUND WATER TABLE ASSUMED AT 5' BELOW GRADE. IF DESIGN (OR ACTUAL) WATER TABLE IS LESS THAN ASSUMED, REVIEWING ENGINEER TO NOTIFY OLDCASTLE PRECAST UPON REVIEW OF THIS SUBMITTAL.
6. LATERAL DESIGN PRESSURES:
  - EQUIV DRY SOIL FLUID PRESSURE = 47 PCF
  - EQUIV SATURATED SOIL FLUID PRESSURE = 80 PSF
  - LIVE LOAD SURCHARGE PRESSURE = 2'
7. CONCRETE COMPRESSIVE STRENGTH AT 28 DAYS = 5,000 PSI.
8. REINFORCEMENT: ASTM A615, GRADE 60.
9. JOINT SEALANT: BUTYL RUBBER, SS-01002/10
10. THESE CALCULATIONS DO NOT INCLUDE ANY LATERAL OR SURCHARGE LOADS PRODUCED BY OTHER FOOTINGS OR FOUNDATIONS ADJACENT TO THIS STRUCTURE. THIS STRUCTURE SHALL BE KEPT A MINIMUM OF 4:1 RATIO AWAY FROM OTHER FOOTINGS OR FOUNDATIONS.

**NOTE TO REVIEWING ENGINEER:**

1. SUPPLY AND INSTALL ALL PIPING AND SAMPLING TEES.
2. DESIGN, AS SHOWN HEREIN, IS APPLICABLE ONLY TO STRUCTURAL PERFORMANCE OF PRECAST. CAPACITY (GALLONS) SHALL BE DETERMINED BY OTHERS BASED ON SPECIFIC PROJECT REQUIREMENT

**NOTE TO CONTRACTOR:**

1. SUPPLY AND INSTALL ALL PIPING AND SAMPLING TEES.
2. GROUT IN ALL PIPES AND WERS.
3. FILL WITH CLEAN WATER PRIOR TO "START UP" OF SYSTEM.
4. VERIFY SIZE AND LOCATION OF ALL OPENINGS.

**APPROX. WEIGHTS**

SECTION	WEIGHT (lb)	CONCRETE (CY)
SLAB FLOOR	4,800	1.19
42" RISER	7,900	1.95
42" TOP	10,700	2.64



THIS DOCUMENT IS THE PROPERTY OF OLDCASTLE PRECAST, INC. IT IS CONFIDENTIAL. SUBMITTED FOR REFERENCE PURPOSES ONLY, AND SHALL NOT BE USED IN ANY WAY UNLESS TO THE INTERESTS OF, OR WITHOUT THE WRITTEN PERMISSION OF OLDCASTLE PRECAST, INC. COPYRIGHT © 2017 OLDCASTLE PRECAST, INC. ALL RIGHTS RESERVED.

**6'-0" x 8'-0" x 6'-11" METER VAULT**

SUBMITTAL LAYOUT

**REVISIONS**

DESCRIPTION OF REVISION

REQUESTED BY

APPROVED W/ NO EXCEPTIONS TAKEN:

APPROVED AS NOTED:

REVISED AND RESUBMIT:

CUSTOMER

DATE: 6/6/17 SALES: DRAWN: ENGINEER: CHECKED: SALES ORDER

DRAWING NUMBER: 60x60.63 Meter Vault REVISION: SHEET

SIGNATURE: DATE: REV DATE: 1 OF 1

REV DATE BY SHEET

A B C D