

Ring & Cover :

*Note: Varies Per Customer Specs

35" x 3" Grade Ring

Weight : 145 Lbs.

24" x 3" Grade Ring

Weight : 105 Lbs.

48" Dia. Flat Slab

Weight : Varies

Flat Slab	
Access	Weight (Lbs.)
24"	1,720
35"	1,700

48" Dia. Conc. Cone

Weight : Varies

Cone	
Access	Weight (Lbs.)
24"	1,550
35"	1,530

48" Dia. Risers

Weight : See Chart

Riser	
A	Weight (Lbs.)
12"	855
24"	1,722
36"	2,589
48"	3,457

48" Dia. Base

Weight : See Chart

** Weights do not include invert

Base	
A	Weight (Lbs.)
38"	**4,749
48"	**5,525

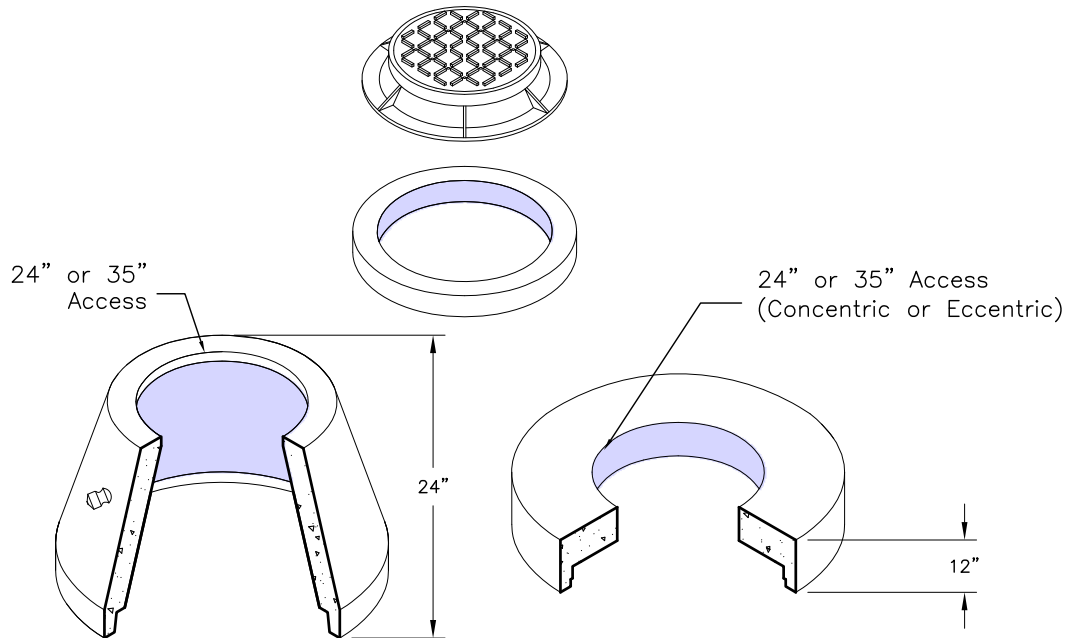

See Joint Detail

24" RCP or Smaller

Lifting Insert (Typ.2) (See Lifting Capacity Diagram)

7,500 LBS.

4,500 PSI

Lifting Capacity



Joint Detail

GENERAL NOTES:

1. Manhole Walls, Transition Slabs, Cones, Tops, and Base Sections Meet or Exceed the Requirements of ASTM C-478.
2. Bedding shall be 6" Cement Stabilized Sand or Select Materials.