

**EXTENSION
 NO. 615-5X**
 24,100 Lbs.

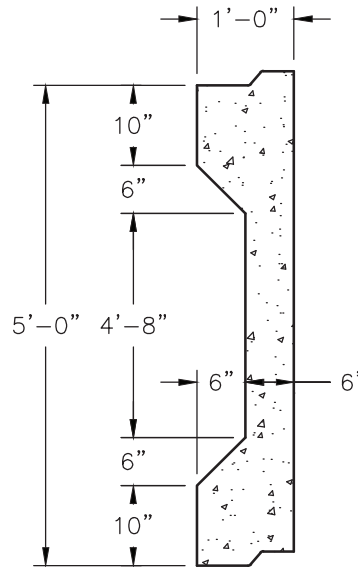

SECTION AT SIDES

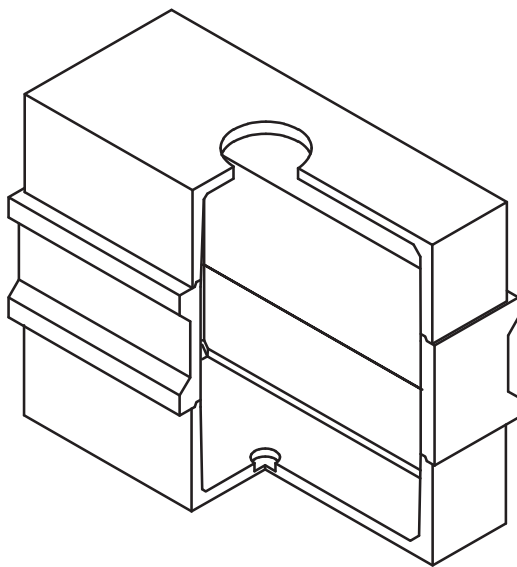
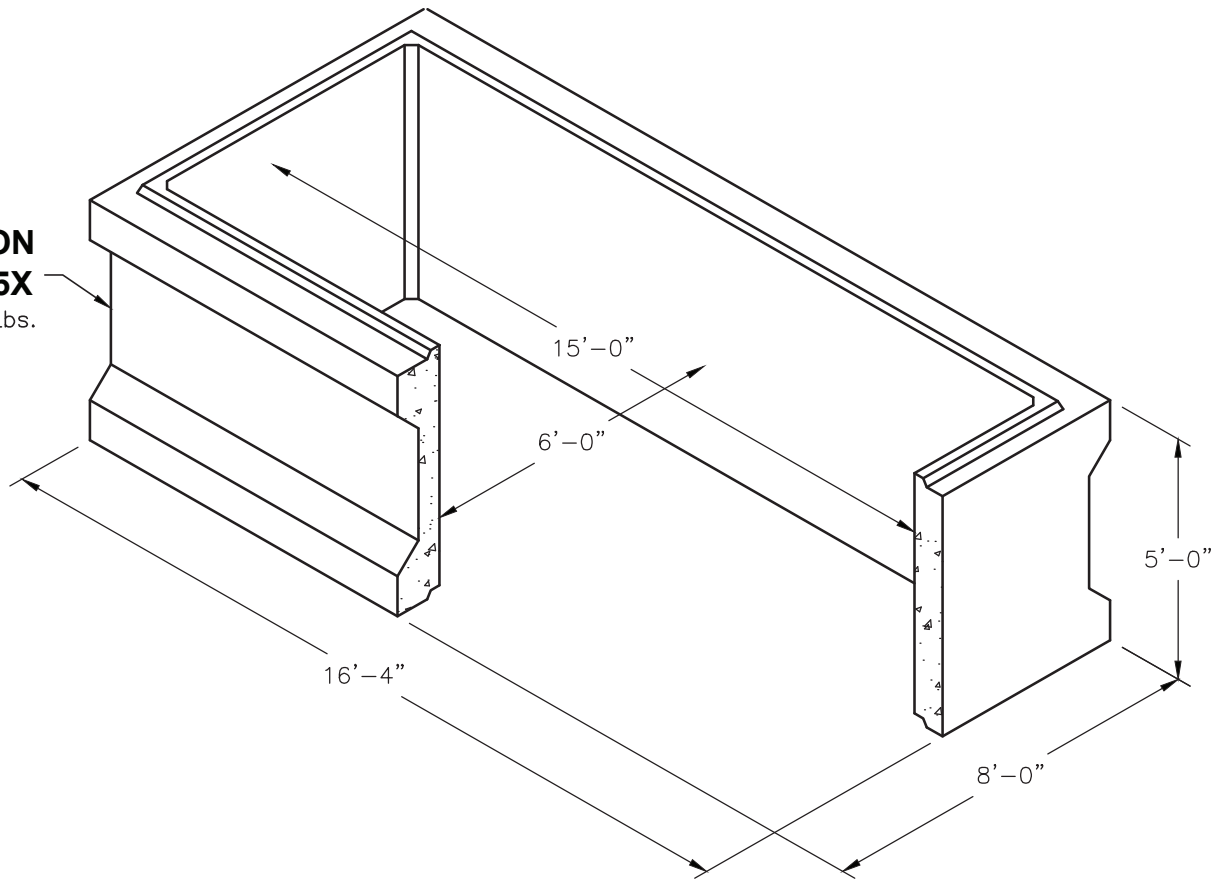
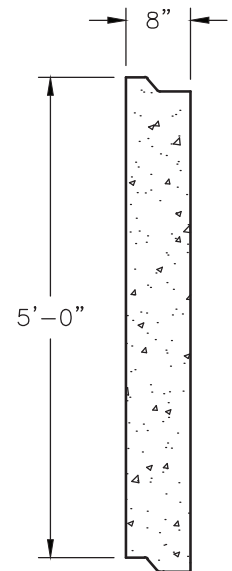

SECTION AT ENDS