

Galv. Steel Traffic Cover
Bolt-Down

(Marked "Elec")
Weight - 290 Lbs.

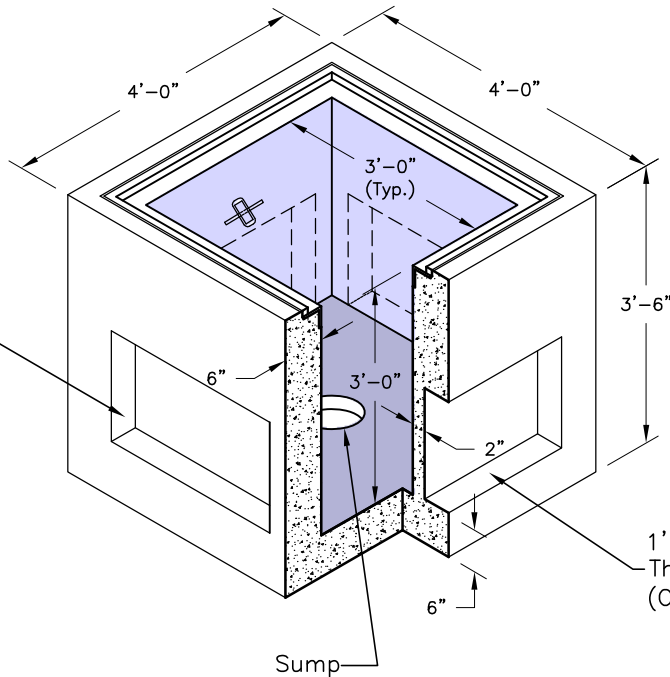

Body w/ Galvanized
Frame

Weight - 3850 Lbs.

1'-0" x 2'-6"
Thin Wall K.O.
(On All Four Sides)

Sump

SPECIFICATIONS:

1. Concrete: Design Strength of 5500 PSI at 28 Days.
2. Steel Reinforcement: ASTM A-615 Grade 60.
3. Loading: Designed for HS-20 Loading.

GENERAL NOTES:

1. Thin Wall Knock Outs Available in Different Sizes Upon Request.
2. All Weights Calculated with Solid Walls.