

6'-0" X 12'-0" X 3'-0" EXTENSION  
 EXTENSION WEIGHT: 8,140 LBS.

ATT-17

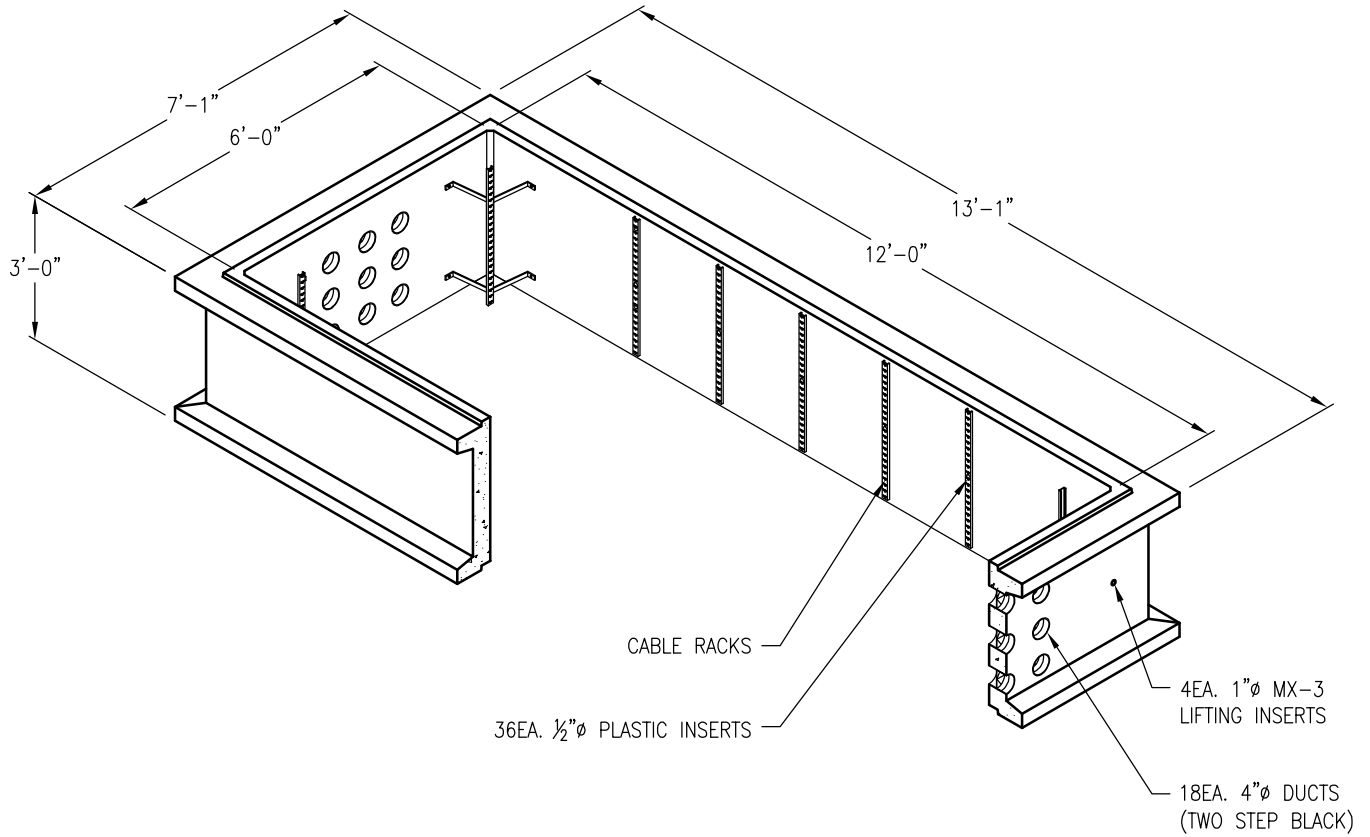

DRAWING MAY NOT CONFORM TO THE  
 MOST CURRENT SPECIFICATION

 **Oldcastle Precast**<sup>®</sup>  
 Northern California  
 Madera ■ Morgan Hill ■ Pleasanton ■ Santa Rosa ■ Stockton ■ Tulare  
 Phone: 925-750-6650 Fax: 925-750-6660

AT&T-38Y612E

FILE NAME: ATT-17.DWG

REVISED: MARCH 2016

[www.oldcastleprecast.com](http://www.oldcastleprecast.com)

6'-0" X 12'-0" X 3'-0" (I.D.)  
 EXTENSION  
 AT&T

Copyright © 2016 **Oldcastle** Precast, Inc.