

6'-0" X 12'-0" X 3'-0" EXTENSION
 PID NO.: 000600122
 EXTENSION WEIGHT: 8,140 LBS.

ATT-19

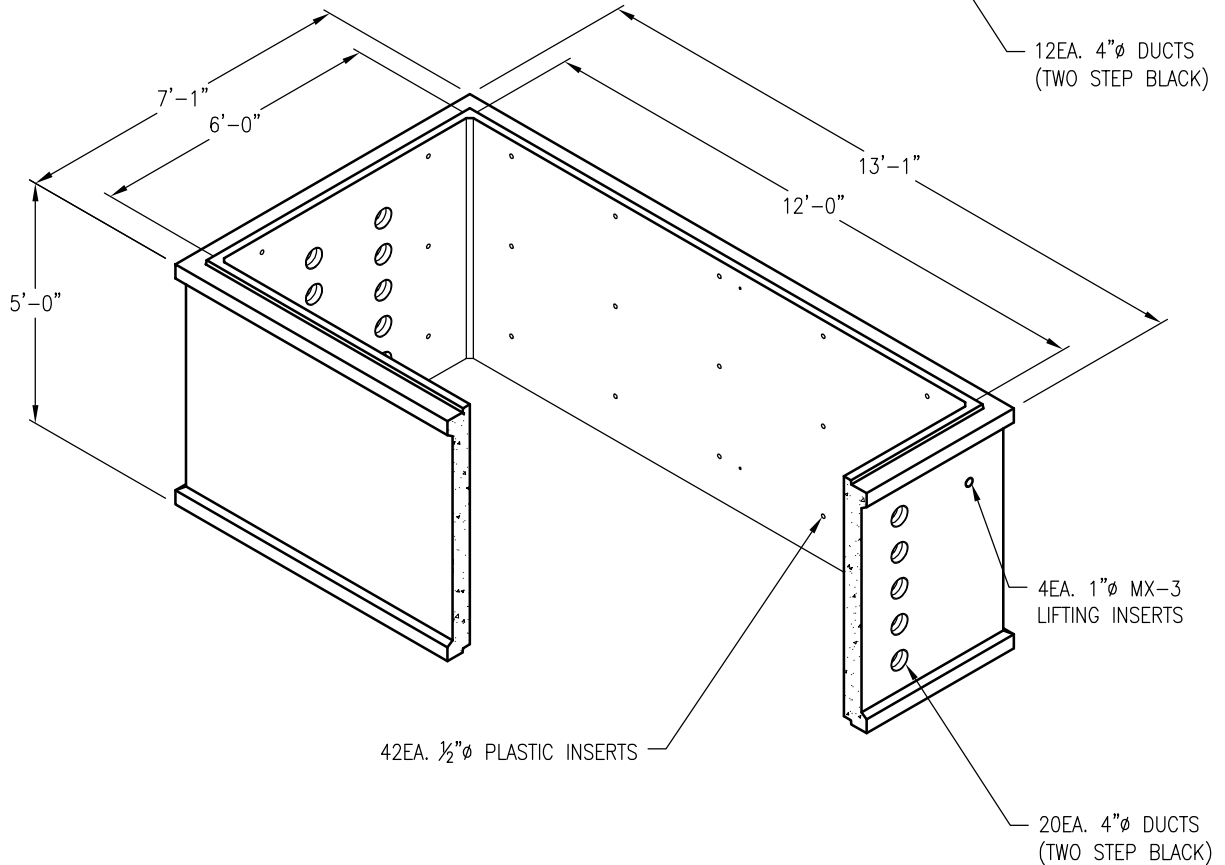
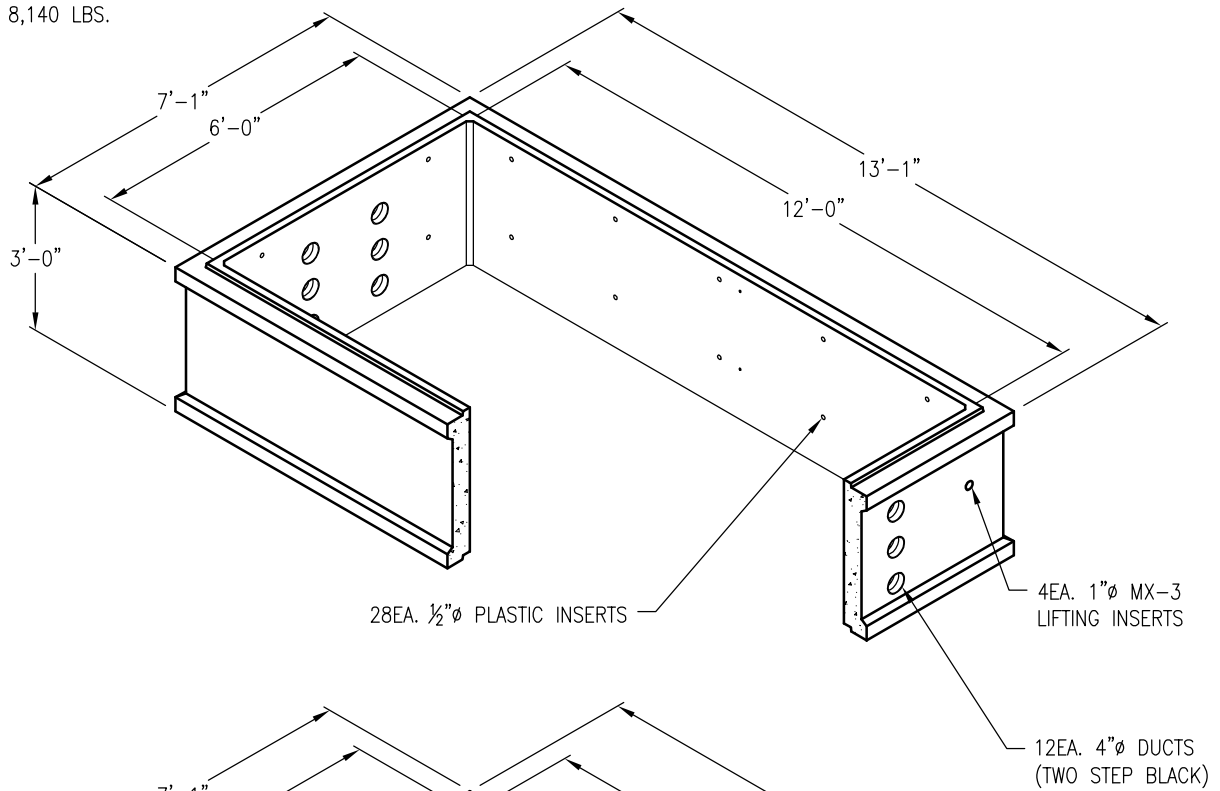

6'-0" X 12'-0" X 5'-0" EXTENSION
 PID NO.: 000600155
 EXTENSION WEIGHT: 14,385 LBS.

DRAWING MAY NOT CONFORM TO THE MOST CURRENT SPECIFICATION



Oldcastle Precast[®]

Northern California
 Madera ■ Morgan Hill ■ Pleasanton ■ Santa Rosa ■ Stockton ■ Tulare
 Phone: 925-750-6650 Fax: 925-750-6660

AT&T-38Y-4049
FILE NAME: ATT-19.DWG
REVISED: MARCH 2016
www.oldcastleprecast.com

6'-0" X 12'-0" X 3'-0" & 5'-0" (I.D.)
 EXTENSIONS
 AT&T

Copyright © 2016 **Oldcastle** Precast, Inc.