

AT&T 3'-0" X 5'-0" X 4'-1 1/2" SUB-SURFACE ENCL. INTERCEPT
 PED HINGED NONSKID
 PID NO.: 000603993
 TRFC HINGED CVR NONSKID
 PID NO.: 000604009
 TRFC BOLT DOWN NONSKID FVT
 PID NO.: 000600056

ATT-6

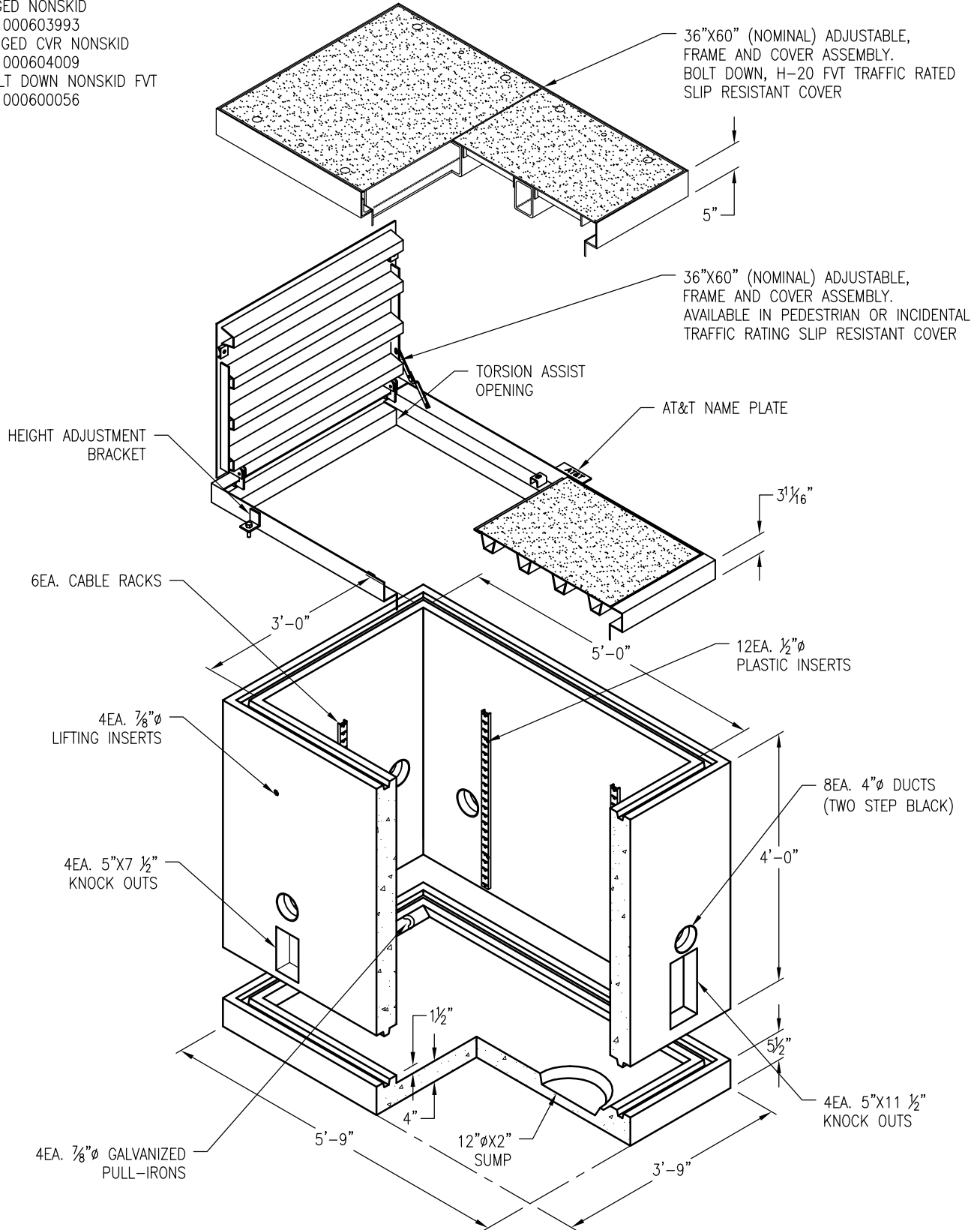

VAULT WEIGHT: 4,020 LBS.
 FLOOR SLAB WEIHT: 1,110 LBS.

DRAWING MAY NOT CONFORM TO THE MOST CURRENT SPECIFICATION

 **Oldcastle Precast**[®]
 Northern California
 Madera ■ Morgan Hill ■ Pleasanton ■ Santa Rosa ■ Stockton ■ Tulare
 Phone: 925-750-6650 Fax: 925-750-6660

AT&T-3660-4 INT
 FILE NAME: ATT-6.DWG
 REVISED: MARCH 2016
www.oldcastleprecast.com

3'-0" X 5'-0" X 4'-1 1/2" (I.D.)
 SUB-SURFACE E. INTERCEPT
 AT&T

Copyright © 2016 Oldcastle Precast, Inc.