

NOTES:

1. WHERE "H" IS 8'-0" OR LESS THE WALL THICKNESS SHALL BE 6". WHERE "H" IS GREATER THAN 8'-0", WALL THICKNESS SHALL BE 8".
2. STEPS SHALL BE INSTALLED ON ALL INLETS WHERE THE HEIGHT IS 30" OR MORE (NOT SHOWN).
3. G2 INLETS ARE MANUFACTURED IN TWO PIECES.
4. 24-13 (600-13) FRAME AND GRATE SHOWN IS SUPPLIED GALVANIZED, UNLESS SPECIFIED OTHERWISE. ALTERNATE CALTRANS GRATES ARE AVAILABLE ON REQUEST.

GRATE TYPE (24-13)
WT=141 LBS
(600-13) METRIC
BICYCLE PROOF

FRAME

OTHER AVAILABLE GRATES:

- GRATE (24-10S) RETICULINE, WT=182 LBS
- GRATE (24-12X) WITH CROSS BARS, WT=192 LBS
- GRATE (24-12) WITH NO CROSS BARS, WT=326 LBS
- GRATE (24-9) WITH NO CROSS BARS, WT=263 LBS

SPECIFY GALVANIZED OR RAW METAL FINISH

GRATES WITHOUT CROSS BARS ARE IN AREAS WHERE THERE ARE NO BICYCLES OR PEDESTRIANS.

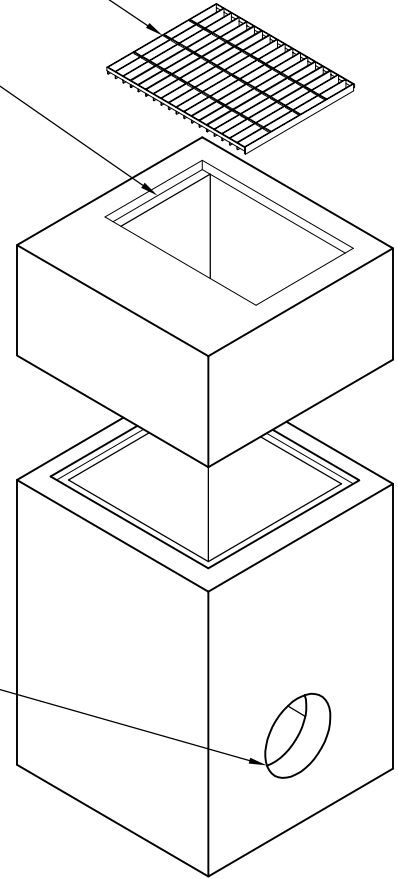

ISOMETRIC VIEW

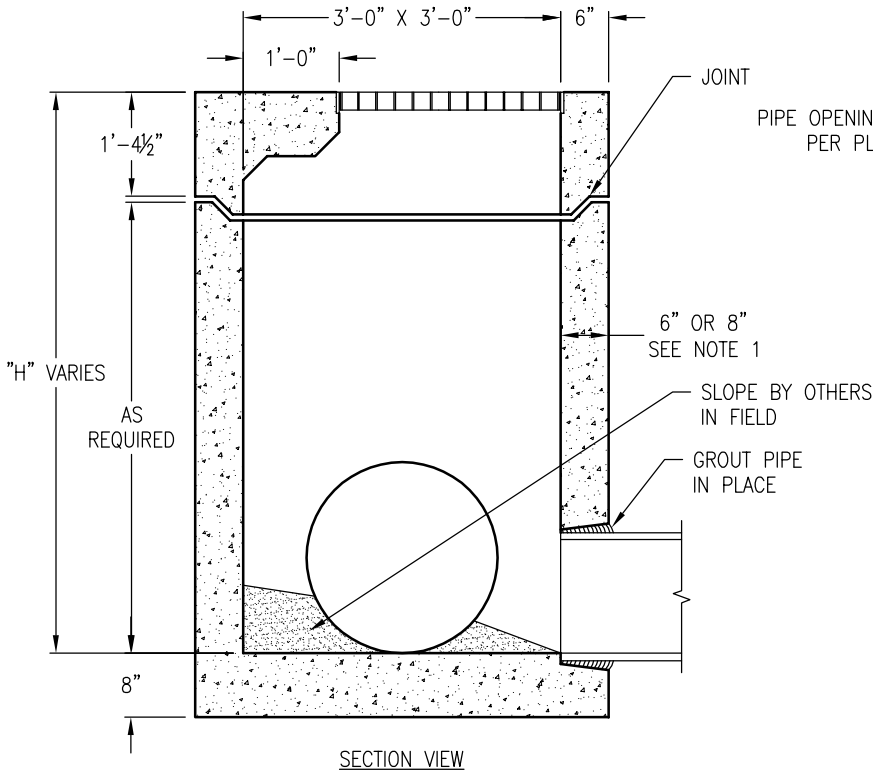

SECTION VIEW

WEIGHT OF FLOOR SLAB IS 1,860 LBS
WEIGHT OF 6" WALL IS 1,050 LBS/FT
WEIGHT OF 8" WALL IS 1,450 LBS/FT

DRAWING MAY NOT CONFORM TO THE MOST CURRENT SPECIFICATION

Oldcastle Precast[®]
Northern California
Madera ■ Morgan Hill ■ Pleasanton ■ Santa Rosa ■ Stockton ■ Tulare
Phone: 925-750-6650 Fax: 925-750-6660

TYPE G2
FILE NAME: CDOT-3.DWG
REVISED: MARCH 2016
www.oldcastleprecast.com

**TYPE G2 3'-0" X 3'-0" (I.D.)
DRAINAGE INLET
CALTRANS**

Copyright © 2016 **Oldcastle** Precast, Inc.