

7'-0" X 11'-0" X 0'-9"
 SWITCH PAD TYPE A
 SWITCH PAD WEIGHT: 7,250 LBS

CPA-10

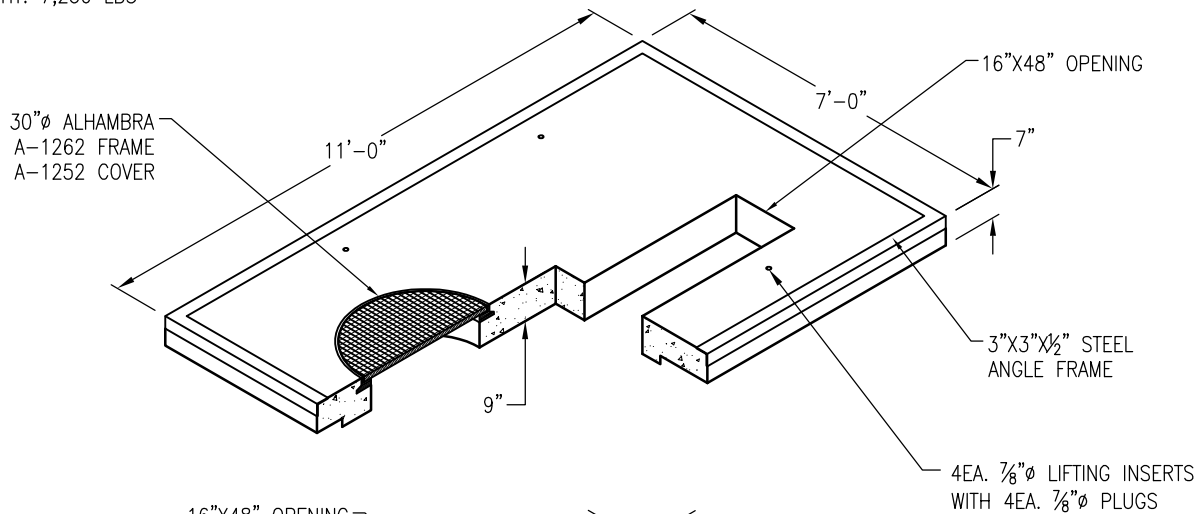

7'-0" X 11'-0" X 0'-9"
 SWITCH PAD TYPE B
 SWITCH PAD WEIGHT: 7,250 LBS

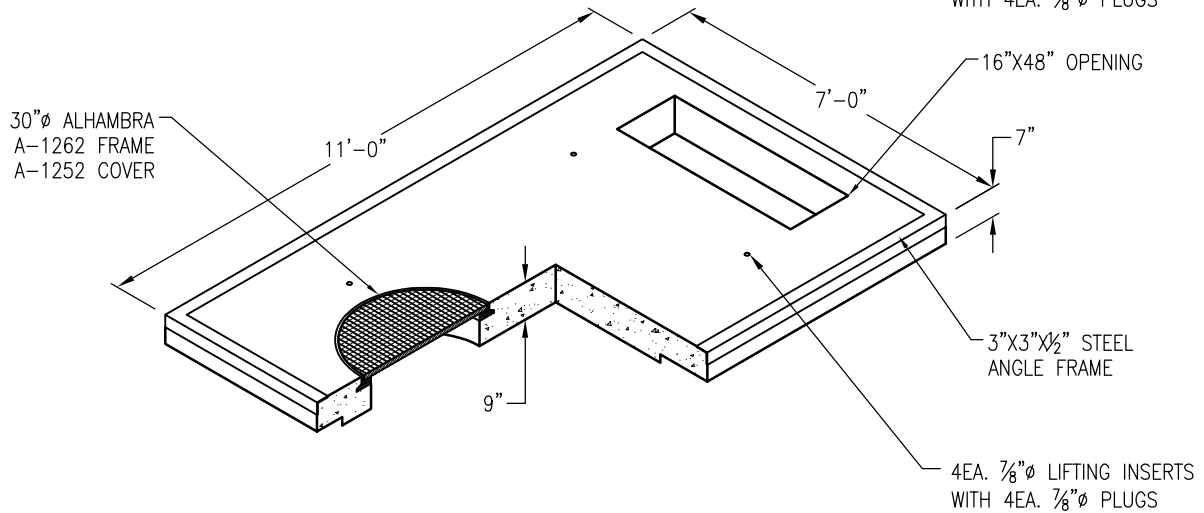
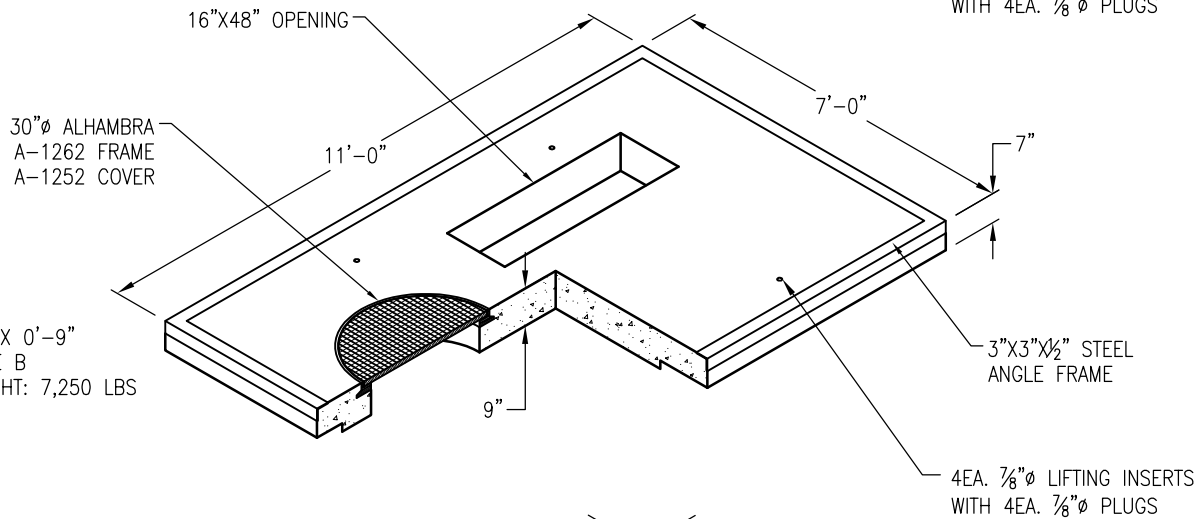

7'-0" X 11'-0" X 0'-9"
 SWITCH PAD TYPE C
 SWITCH PAD WEIGHT: 7,250 LBS

DRAWING MAY NOT CONFORM TO THE
 MOST CURRENT SPECIFICATION



Oldcastle Precast[®]
 Northern California
 Madera ■ Morgan Hill ■ Pleasanton ■ Santa Rosa ■ Stockton ■ Tulare
 Phone: 925-750-6650 Fax: 925-750-6660

CPA-SWITCH PAD
FILE NAME: CPA-10.DWG
REVISED: MARCH 2016
www.oldcastleprecast.com

7'-0" X 11'-0" X 0'-9" (O.D.)
 SWITCH PAD A, B, & C
 CITY OF PALO ALTO

Copyright © 2016 Oldcastle Precast, Inc.