

3'-6" X 5'-6" X 5'-3" VAULT  
FOR REPLACEMENT PARTS

CPA-5

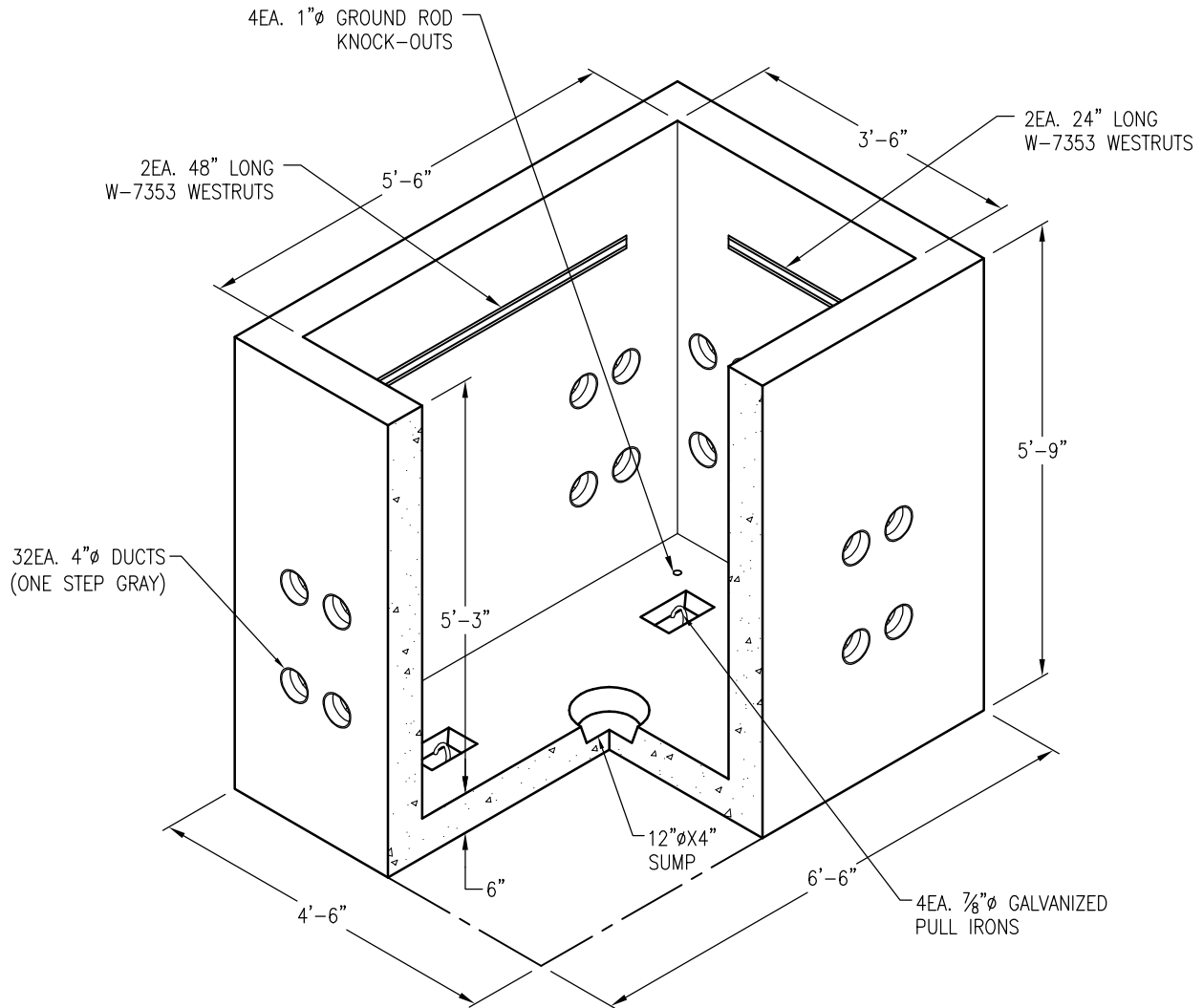
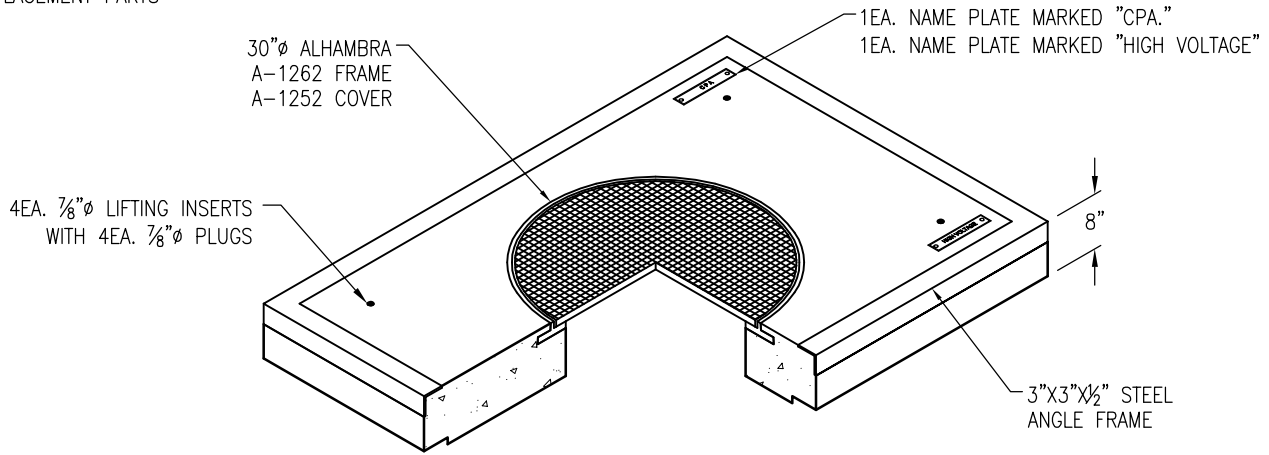

TOP SLAB WEIGHT: 3,000 LBS  
VAULT WEIGHT: 10,300 LBS

DRAWING MAY NOT CONFORM TO THE  
MOST CURRENT SPECIFICATION

 **Oldcastle Precast**<sup>®</sup>  
Northern California  
Madera ■ Morgan Hill ■ Pleasanton ■ Santa Rosa ■ Stockton ■ Tulare  
Phone: 925-750-6650 Fax: 925-750-6660

CPA-660-LA

FILE NAME: CPA-5.DWG

REVISED: MARCH 2016

[www.oldcastleprecast.com](http://www.oldcastleprecast.com)

3'-6" X 5'-6" X 5'-3" (I.D.)  
UTILITY VAULT  
CITY OF PALO ALTO

Copyright © 2016 **Oldcastle** Precast, Inc.