

NOTE:
CONVAULT EQUIPMENT AND LAYOUT
VARIES TO SPECIFIC CUSTOMER NEEDS

CVT-4

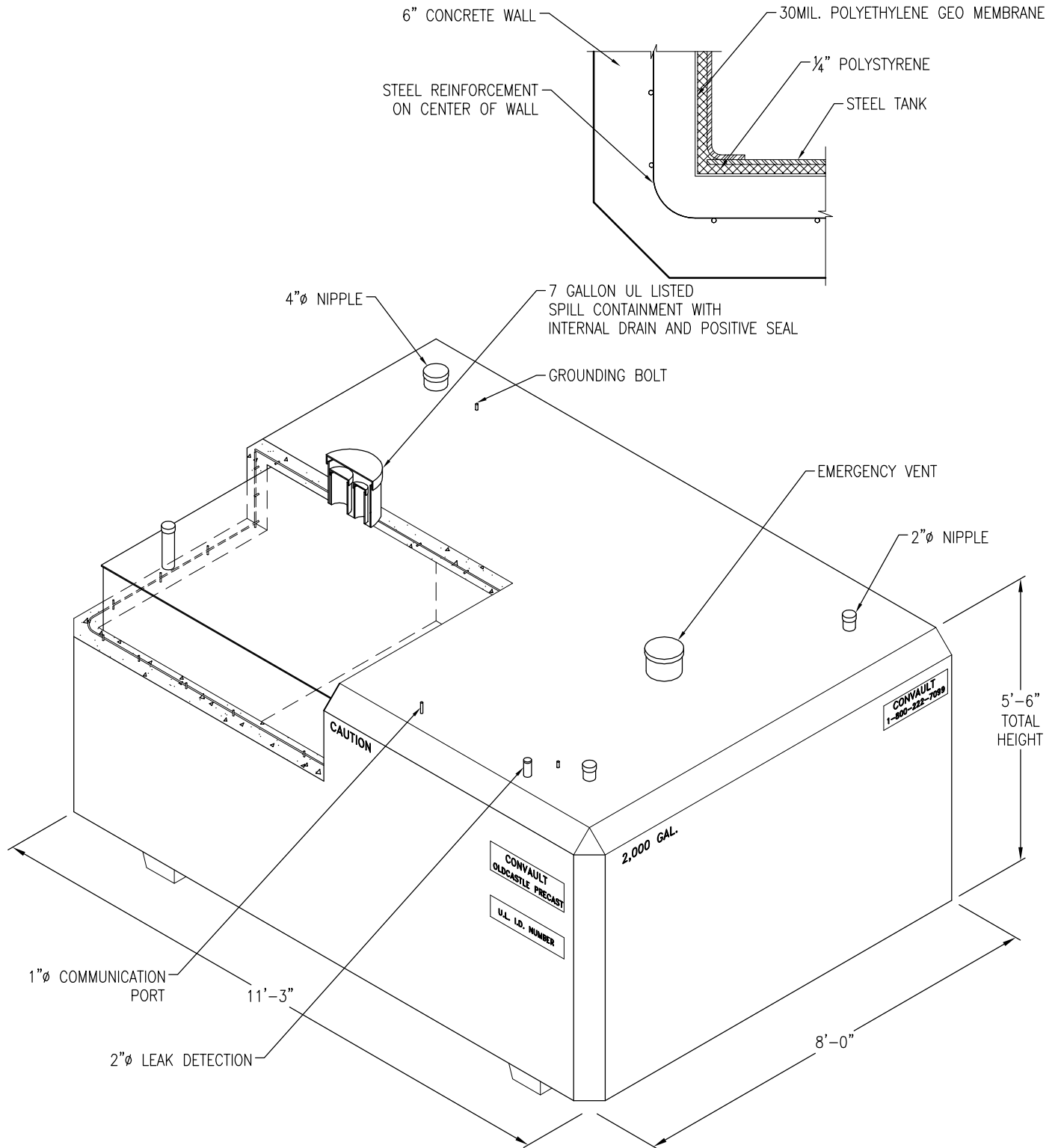

MEETS UL2085 & UL752 LEVEL 8
APPROXIMATE WEIGHT:
WITHOUT EQUIPMENT 30,000 LBS

DRAWING MAY NOT CONFORM TO THE
MOST CURRENT SPECIFICATION

 **Oldcastle Precast**[®]
Northern California
Madera ■ Morgan Hill ■ Pleasanton ■ Santa Rosa ■ Stockton ■ Tulare
Phone: 925-750-6650 Fax: 925-750-6660

CVT-2000G
FILE NAME: CVT-4.DWG
REVISED: MARCH 2016
www.oldcastleprecast.com

8'-0" X 11'-3 X 5'-6"
CONVAULT
OLDCASTLE PRECAST

Copyright © 2016 **Oldcastle** Precast, Inc.