

300 TOTAL GALLON OIL/WATER SEPARATOR
 CUSTOMER TO SUPPLY PIPES AND TEES.
 PIPING SHOWN FOR REFERENCE ONLY.

ENV-1

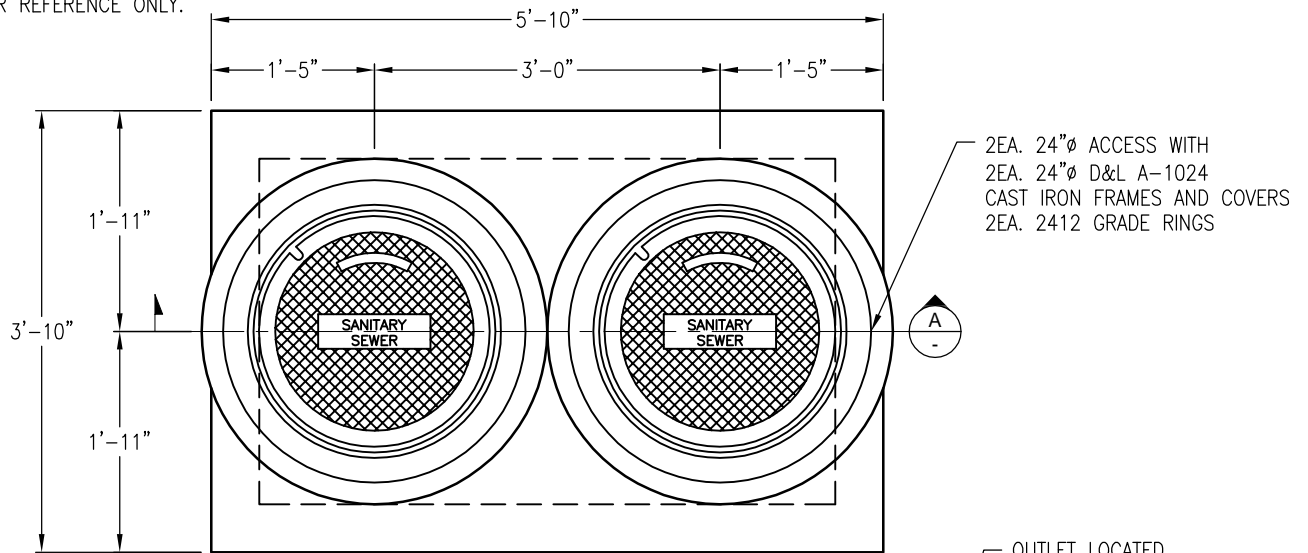

2EA. 24"Ø ACCESS WITH
 2EA. 24"Ø D&L A-1024
 CAST IRON FRAMES AND COVERS
 2EA. 2412 GRADE RINGS

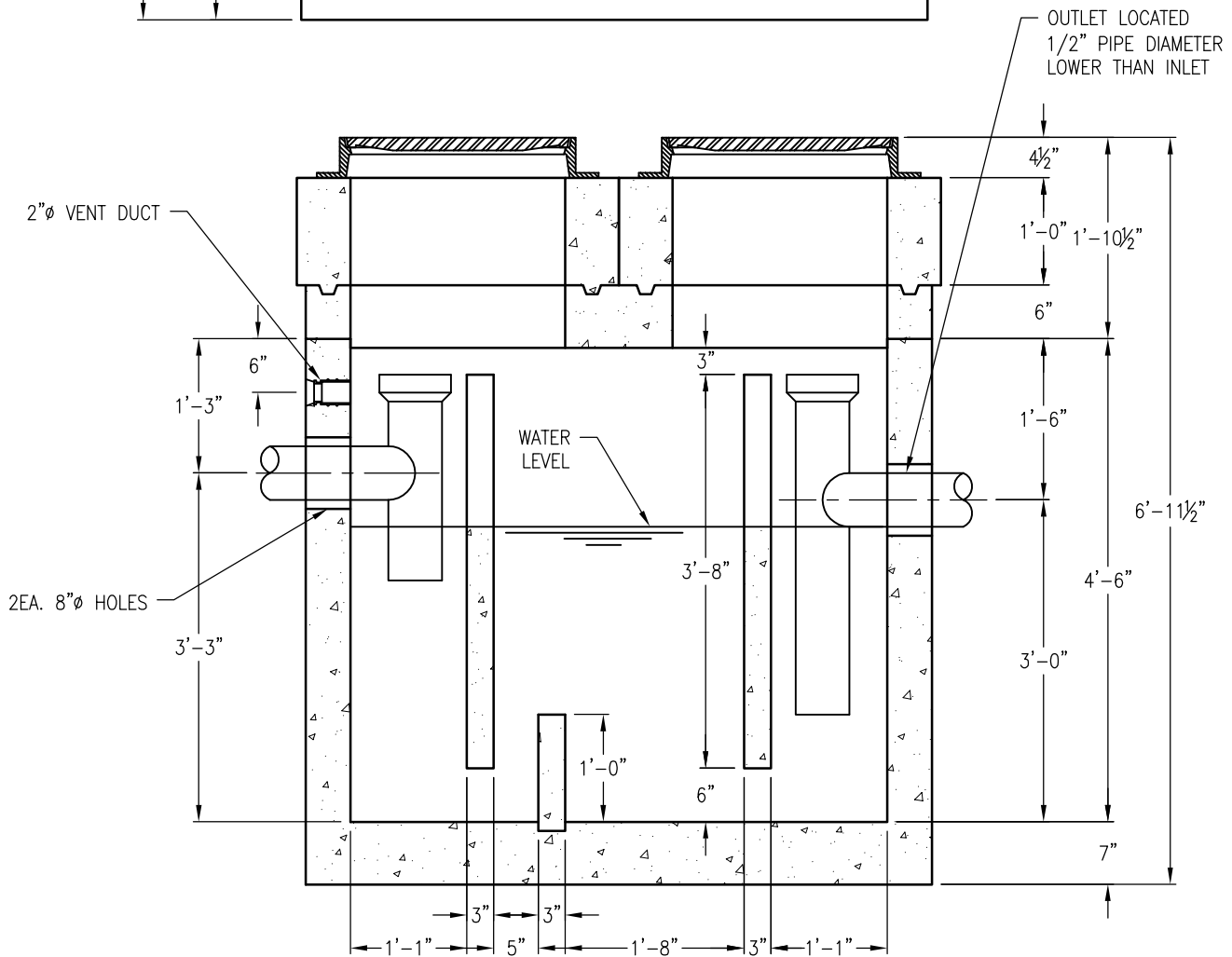

OUTLET LOCATED
 1/2" PIPE DIAMETER
 LOWER THAN INLET

TOP SLAB WEIGHT: 1,500 LBS.
 VAULT WEIGHT: 7,100 LBS.

DRAWING MAY NOT CONFORM TO THE
 MOST CURRENT SPECIFICATION

Oldcastle Precast[®]
 Northern California
 Madera ■ Morgan Hill ■ Pleasanton ■ Santa Rosa ■ Stockton ■ Tulare
 Phone: 925-750-6650 Fax: 925-750-6660

OWS-3546
FILE NAME: ENV-1.DWG
REVISED: MARCH 2016
www.oldcastleprecast.com

**3'-0" X 5'-0" X 4'-6" (I.D.)
 ENVIRONMENTAL VAULT
 OIL WATER SEPARATOR**

Copyright © 2016 **Oldcastle** Precast, Inc.