

800 TOTAL GALLON OIL/WATER SEPARATOR  
 CUSTOMER TO SUPPLY PIPES AND TEES.  
 PIPING SHOWN FOR REFERENCE ONLY.

ENV-2

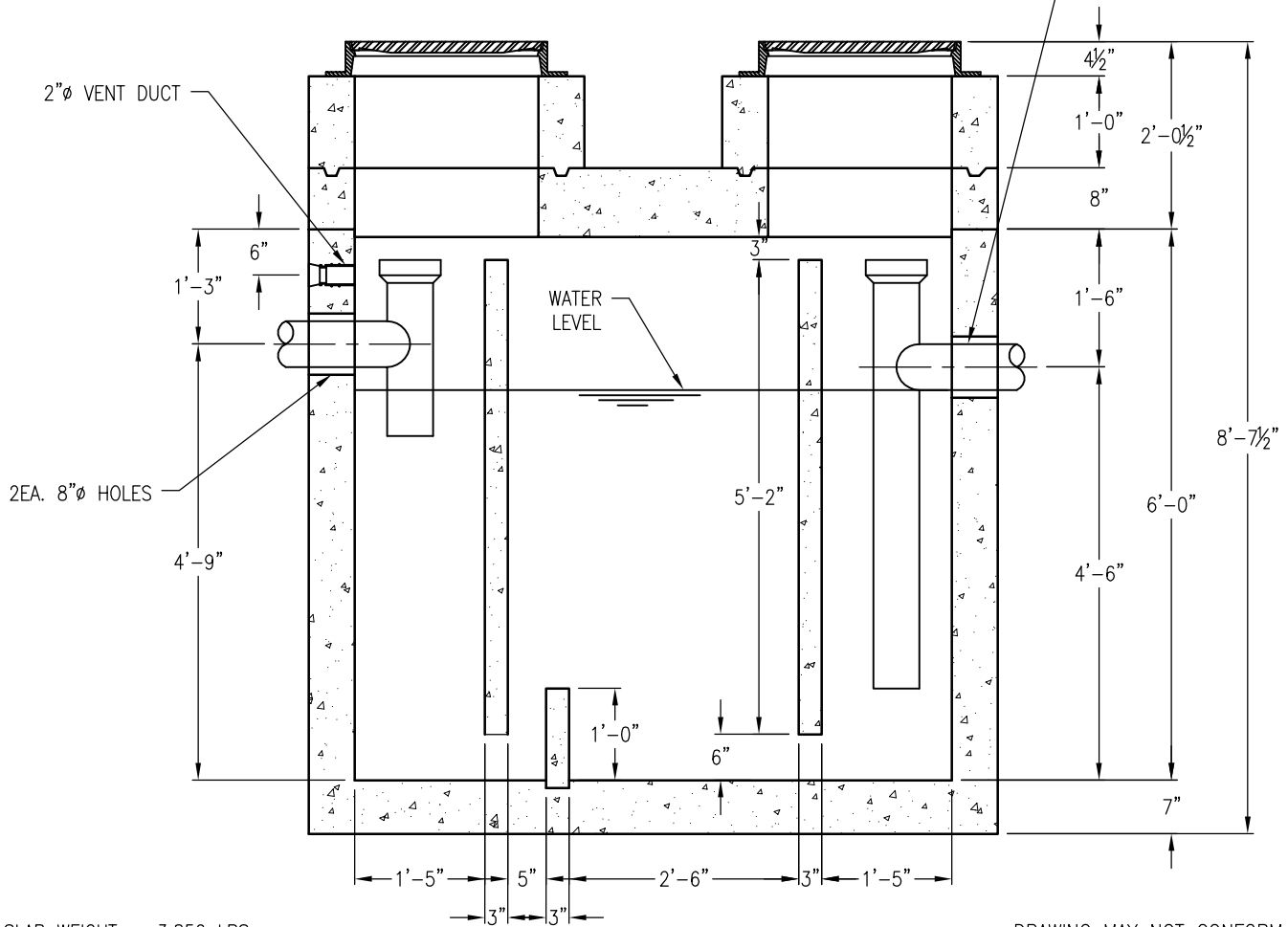
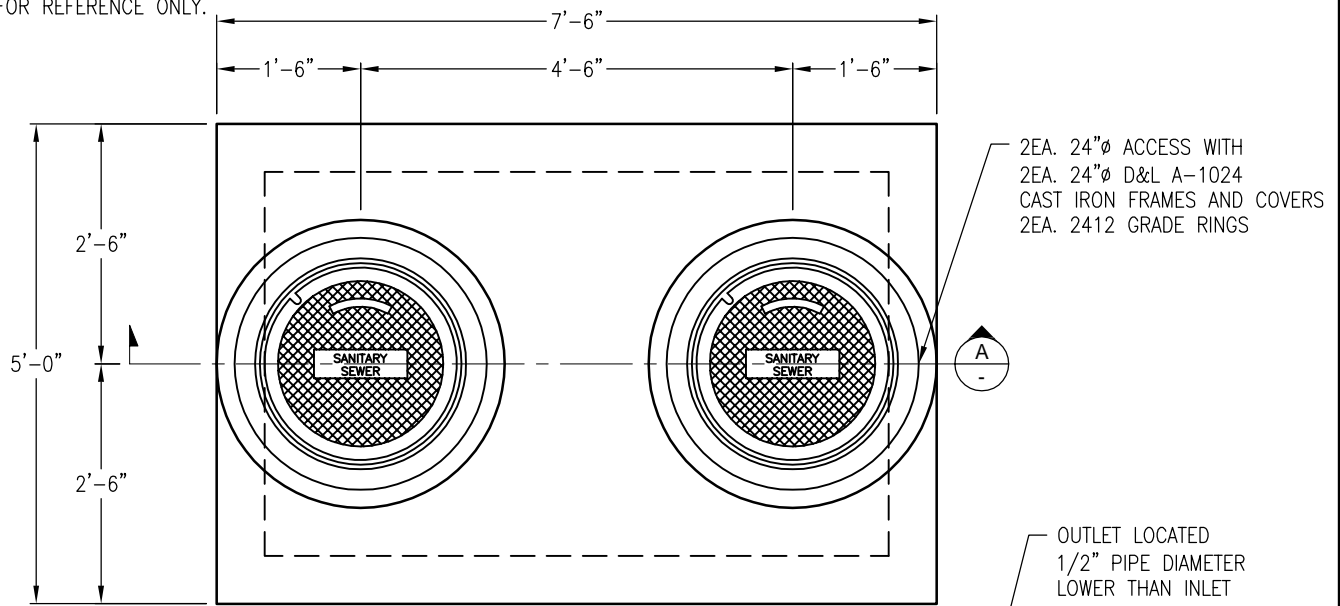

TOP SLAB WEIGHT: 3,850 LBS.  
 VAULT WEIGHT: 13,160 LBS.

DRAWING MAY NOT CONFORM TO THE MOST CURRENT SPECIFICATION