

800 TOTAL GALLON OIL/WATER SEPARATOR
 CUSTOMER TO SUPPLY PIPES AND TEES.
 PIPING SHOWN FOR REFERENCE ONLY.

ENV-7

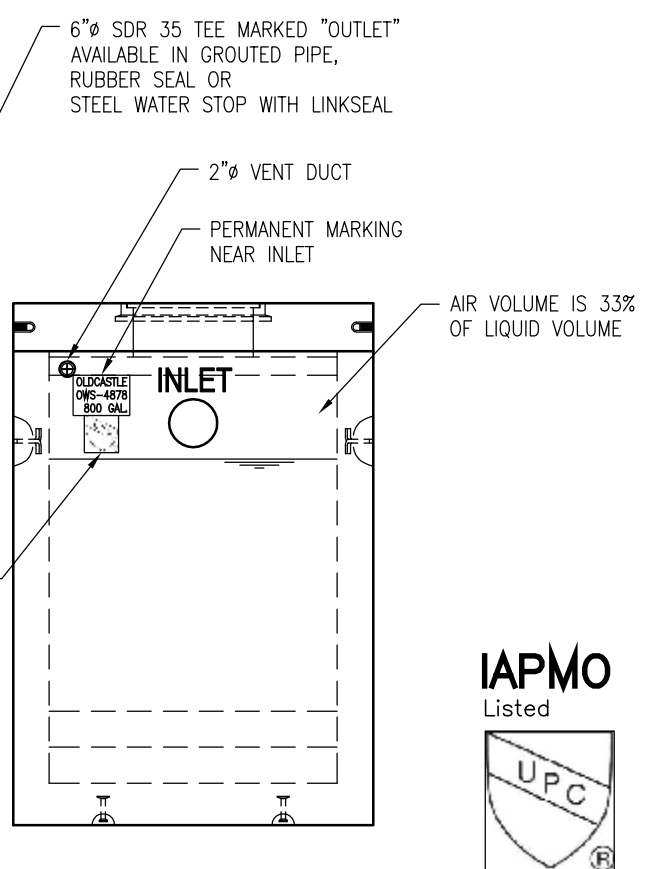
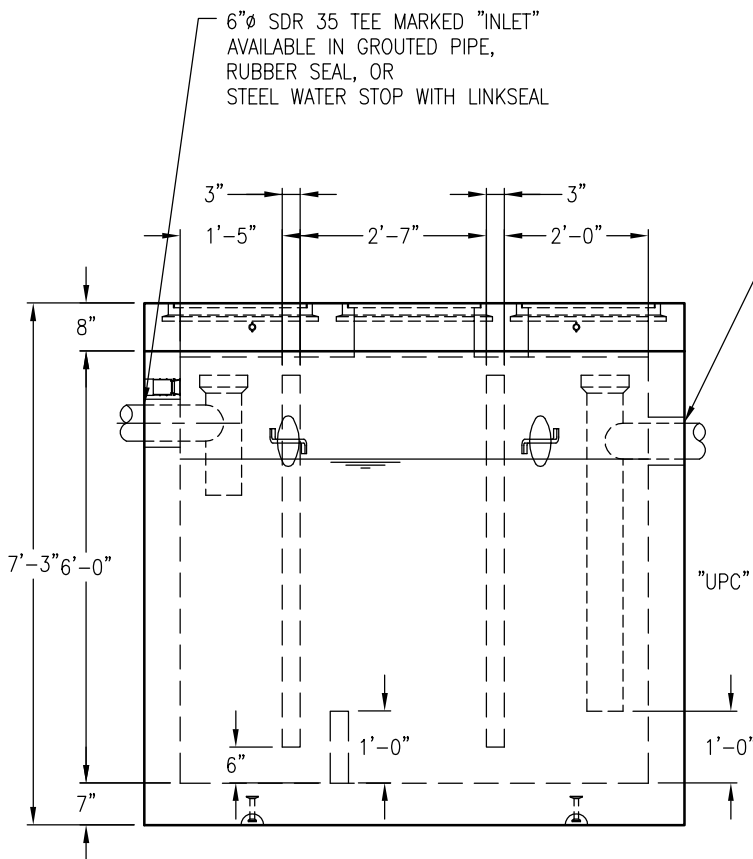
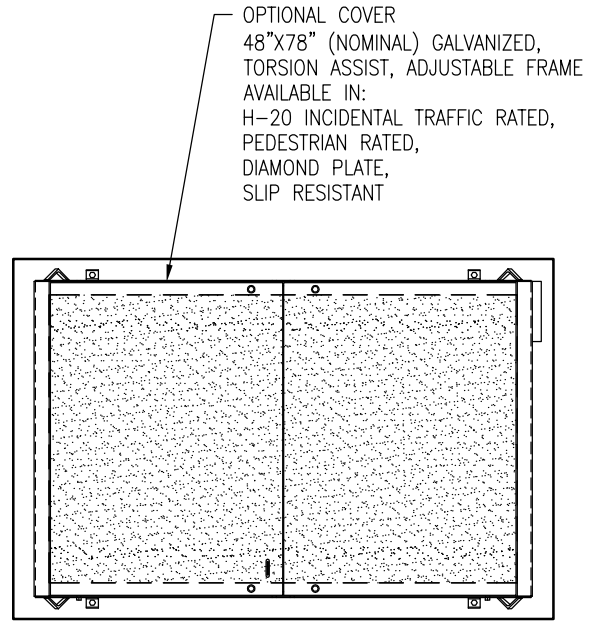
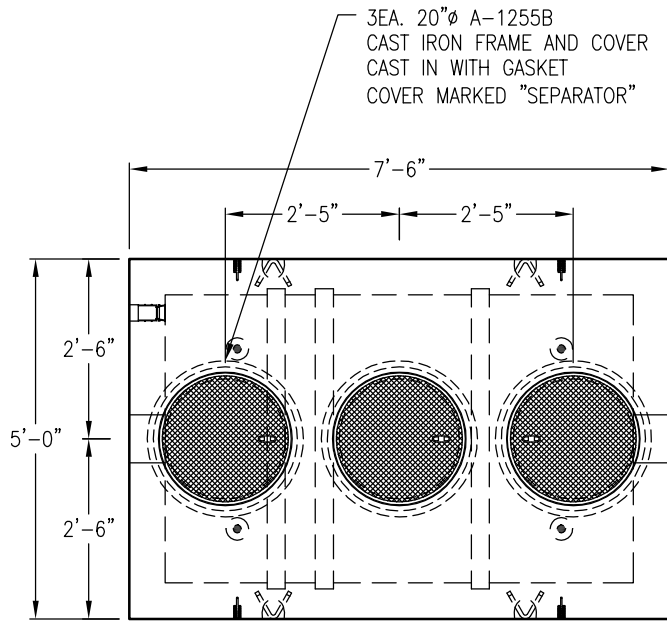

TOP SLAB WEIGHT: 3,940 LBS.
 VAULT WEIGHT: 13,900 LBS.

DRAWING MAY NOT CONFORM TO THE
 MOST CURRENT SPECIFICATION

Oldcastle Precast[®]

Northern California
 Madera ■ Morgan Hill ■ Pleasanton ■ Santa Rosa ■ Stockton ■ Tulare
 Phone: 925-750-6650 Fax: 925-750-6660

OWS-4878
FILE NAME: ENV-7.DWG
REVISED: MARCH 2016
www.oldcastleprecast.com

4'-0" X 6'-6" X 6'-0" (I.D.)
 ENVIRONMENTAL VAULT
 OIL WATER SEPARATOR

Copyright © 2016 Oldcastle Precast, Inc.