

### SPECIFIER CHART

MODEL	INLET ID	GRATE OD	COMMENTS
FF-12D	12" X 12"	15" X 15"	GRATED INLET
FF-16D	16" X 16"	18" X 18"	GRATED INLET
FF-18D	18" X 18"	20" X 20"	GRATED INLET
FF-1836SD	18" X 36"	18" X 40"	GRATED INLET
FF-1836DGO	18" X 36"	18" X 40"	COMBINATION INLET
FF-24D	24" X 24"	26" X 26"	GRATED INLET
FF-2436SD	24" X 36"	24" X 40"	GRATED INLET
FF-24DGO	24" X 24"	18" X 26"	COMBINATION INLET
FF-2436DGO	24" X 36"	24" X 40"	COMBINATION INLET
FF-36D (2 PIECE)	36" X 36"	36" X 40"	GRATED INLET
FF-3648D (2 PIECE)	36" X 48"	40" X 48"	GRATED INLET

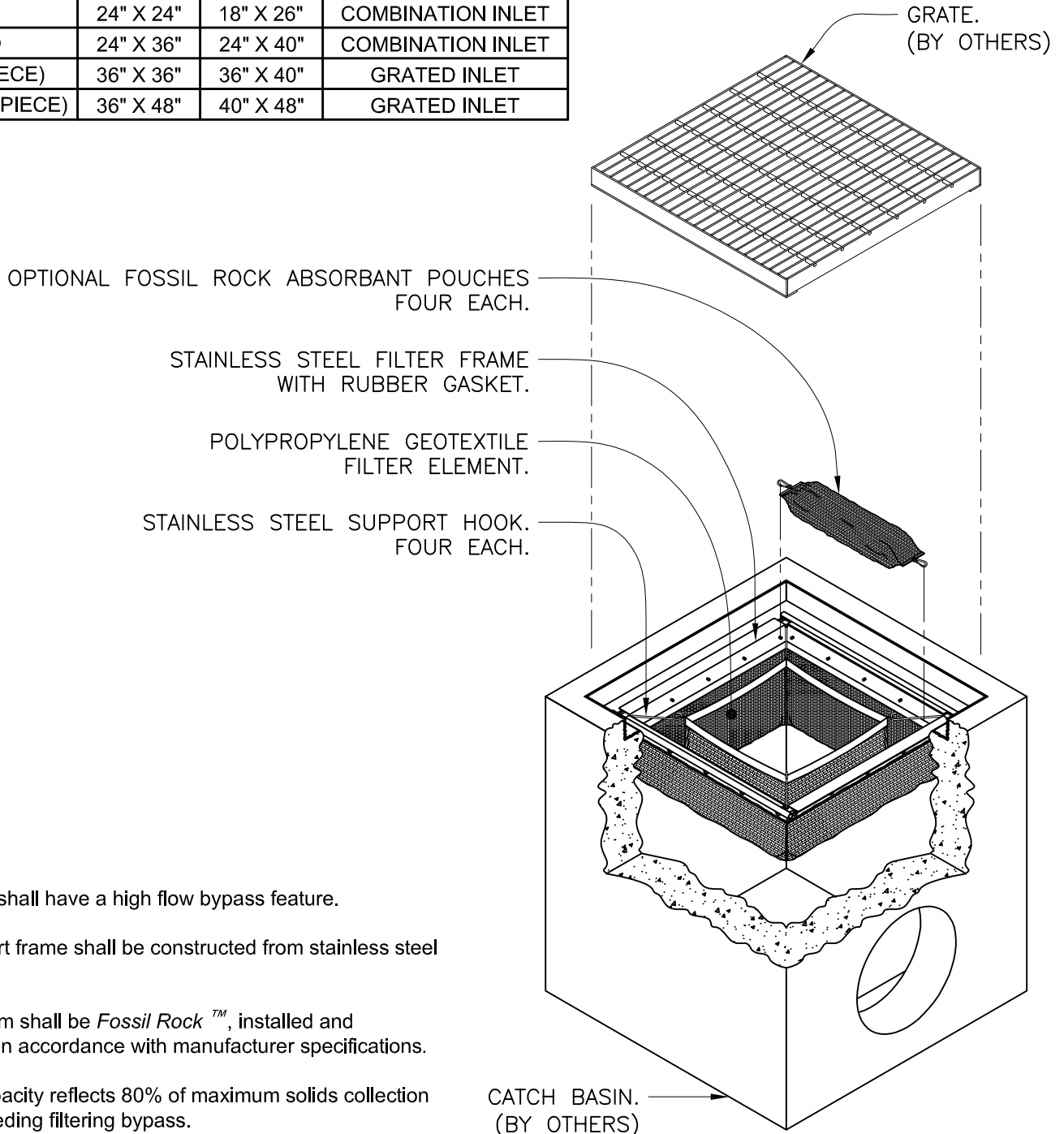

**NOTES:**

1. Filter insert shall have a high flow bypass feature.
2. Filter support frame shall be constructed from stainless steel Type 304.
3. Filter medium shall be *Fossil Rock™*, installed and maintained in accordance with manufacturer specifications.
4. Storage capacity reflects 80% of maximum solids collection prior to impeding filtering bypass.



Inlet  
Filtration

**FloGard®**  
Catch Basin Insert Filter  
Grated Inlet Style



**Oldcastle®**  
Stormwater Solutions

7921 Southpark Plaza, Suite 200 | Littleton, CO | 80120 | Ph: 800.579.8819 | oldcastlestormwater.com  
THIS DOCUMENT IS THE PROPERTY OF OLDCASTLE PRECAST, INC. IT IS SUBMITTED FOR REFERENCE PURPOSES ONLY AND SHALL NOT BE USED IN ANY WAY INJURIOUS TO THE INTERESTS OF SAID COMPANY. COPYRIGHT © 2016 OLDCASTLE PRECAST, INC. ALL RIGHTS RESERVED.

DRAWING NO. FG-0001	REV E	ECO ECO-0142	DATE JPR 7/13/16	DATE JPR 12/18/06	SHEET 1 OF 2
------------------------	----------	-----------------	---------------------	----------------------	--------------

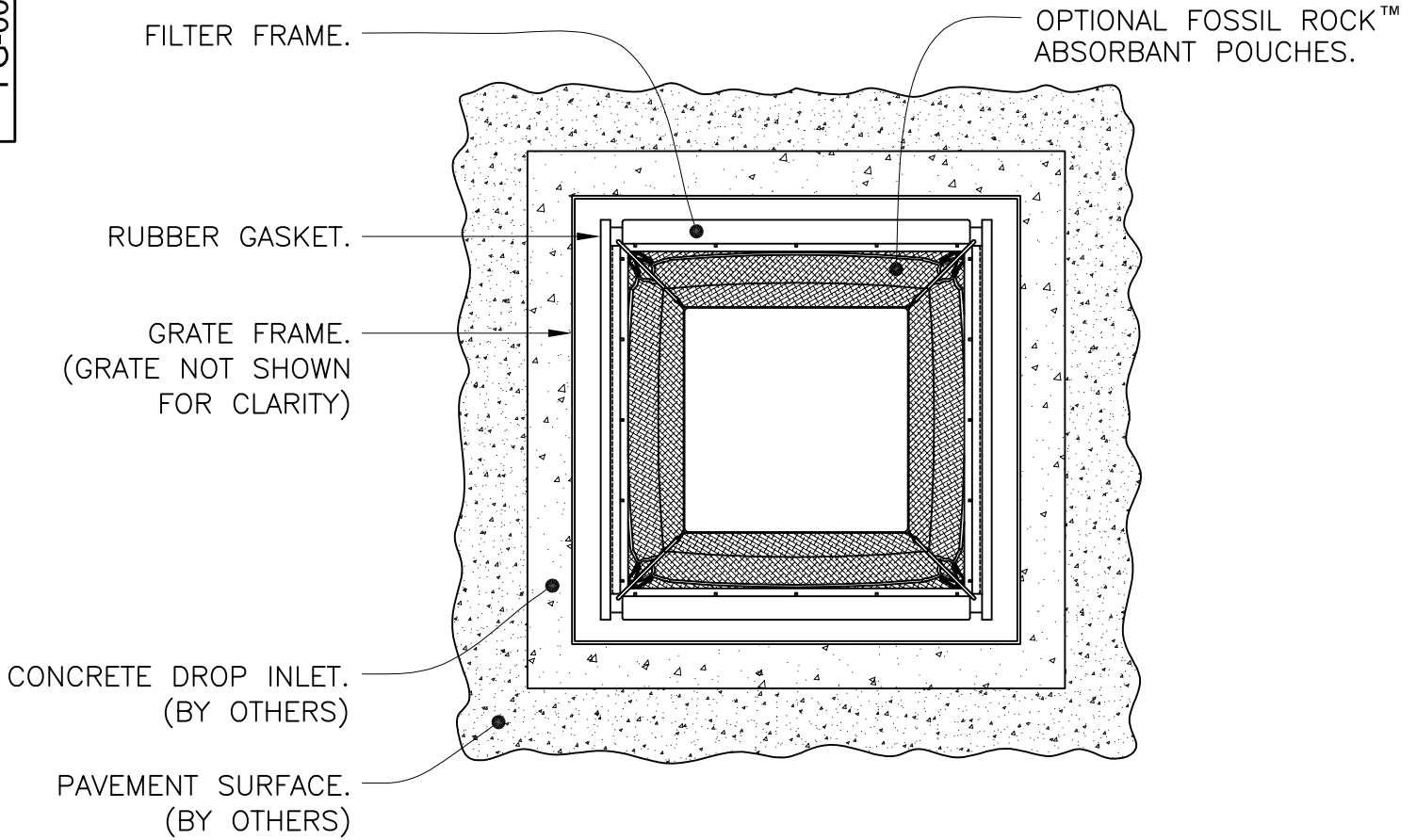

REFER TO SPECIFIER CHART FOR CATCH BASIN & FILTER SIZING. SEE SHEET 1 OF 2.

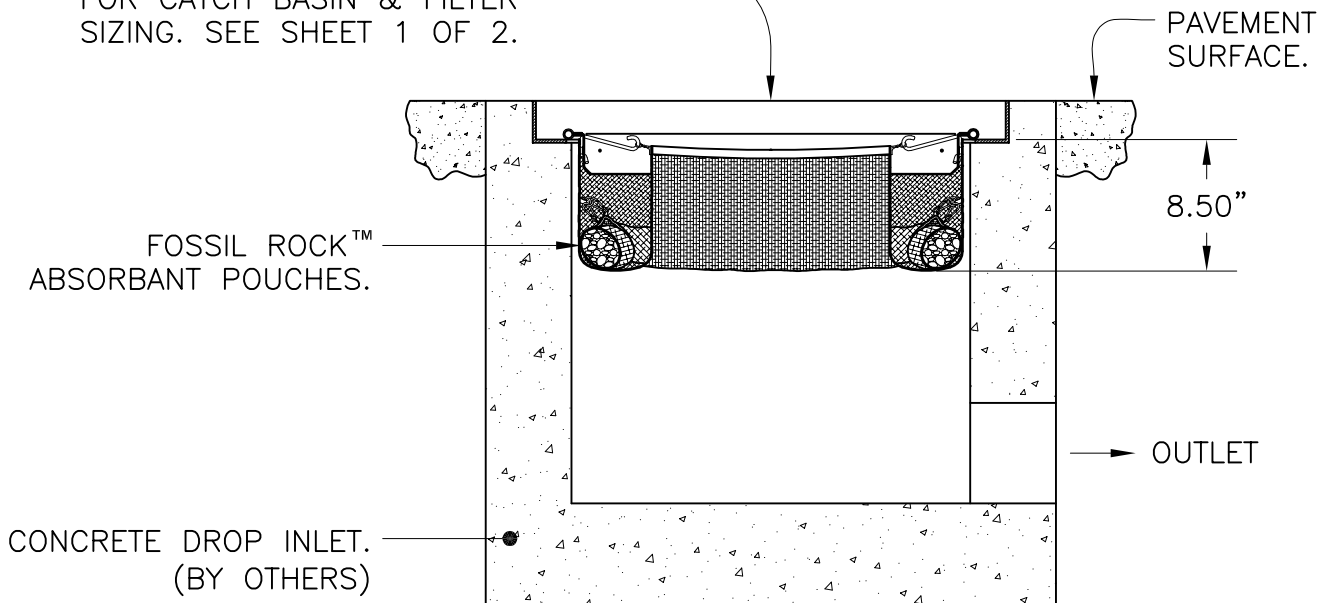

**SECTION VIEW**



Inlet Filtration

**FloGard®**  
*Catch Basin Insert Filter*  
*Grated Inlet Style*



**Oldcastle®**  
 Stormwater Solutions

7921 Southpark Plaza, Suite 200 | Littleton, CO | 80120 | Ph: 800.579.8819 | oldcastlestormwater.com

THIS DOCUMENT IS THE PROPERTY OF OLDCASTLE PRECAST, INC. IT IS SUBMITTED FOR REFERENCE PURPOSES ONLY AND SHALL NOT BE USED IN ANY WAY INJURIOUS TO THE INTERESTS OF SAID COMPANY. COPYRIGHT © 2016 OLDCASTLE PRECAST, INC. ALL RIGHTS RESERVED.

DRAWING NO. FG-0001	REV E	ECO ECO-0142	DATE JPR 7/13/16	DATE JPR 12/18/06	SHEET 2 OF 2
------------------------	----------	-----------------	---------------------	----------------------	--------------