

SPECIFIER CHART		
MODEL NO.	CATCH BASIN ID Inside Dimension (inch x inch)	CURB DAM OPTION (YES / NO)
FG-TB24	24 X 24	NO
FG-TB24D	24 X 24	YES
FG-TB2436	24 X 36	NO
FG-TB2436D	24 X 36	YES
FG-TB36	36 X 36	NO
FG-TB36D	36 X 36	YES

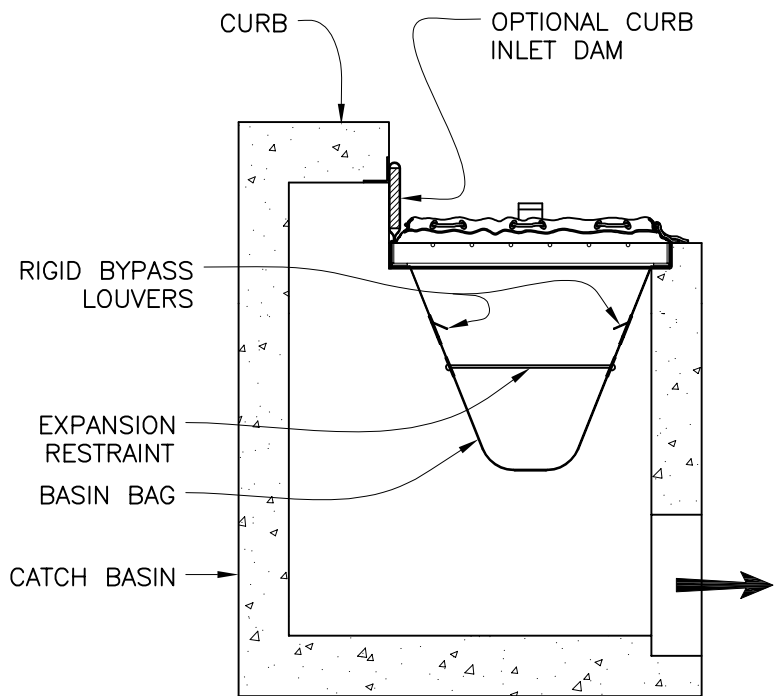

**SECTION VIEW**  
**-INSTALLED-**  
WITH OPTIONAL CURB INLET DAM

**NOTES:**

1. FloGard® T-Bag™ is manufactured from woven monofilament polypropylene fabric.
2. May be ordered with *Fossil Rock™* oil absorbent pouches installed.
3. Optional curb inlet dam available upon request.
4. Periodic maintenance is required. FloGard® T-Bag™ should never be allowed to fill beyond the top of the bypass louvers.
5. Appropriate lifting equipment should be used when performing periodic maintenance.



**FloGard® T-BAG™**  
*Temporary*  
**Inlet Protection Device**



**Oldcastle®**  
Stormwater Solutions

7921 Southpark Plaza, Suite 200 | Littleton, CO | 80120 | Ph: 800.579.8819 | oldcastlestormwater.com  
THIS DOCUMENT IS THE PROPERTY OF OLDCASTLE PRECAST, INC. IT IS SUBMITTED FOR REFERENCE PURPOSES ONLY AND SHALL NOT BE USED IN ANY WAY INJURIOUS TO THE INTERESTS OF SAID COMPANY. COPYRIGHT © 2010 OLDCASTLE PRECAST, INC. ALL RIGHTS RESERVED.

DRAWING NO. FG-TB-0001	REV B	ECO ECO-0127	DATE JPR 5/18/15	DATE JPR 09/01/06	SHEET 1 OF 1
---------------------------	----------	-----------------	---------------------	----------------------	--------------