

**LID SECTION**
**466 Cab Fuse Pad**

Weight = 2,443 lbs.

**RISER SECTION**
**466 Cab Fuse Pit**

Weight = 5,038 lbs.

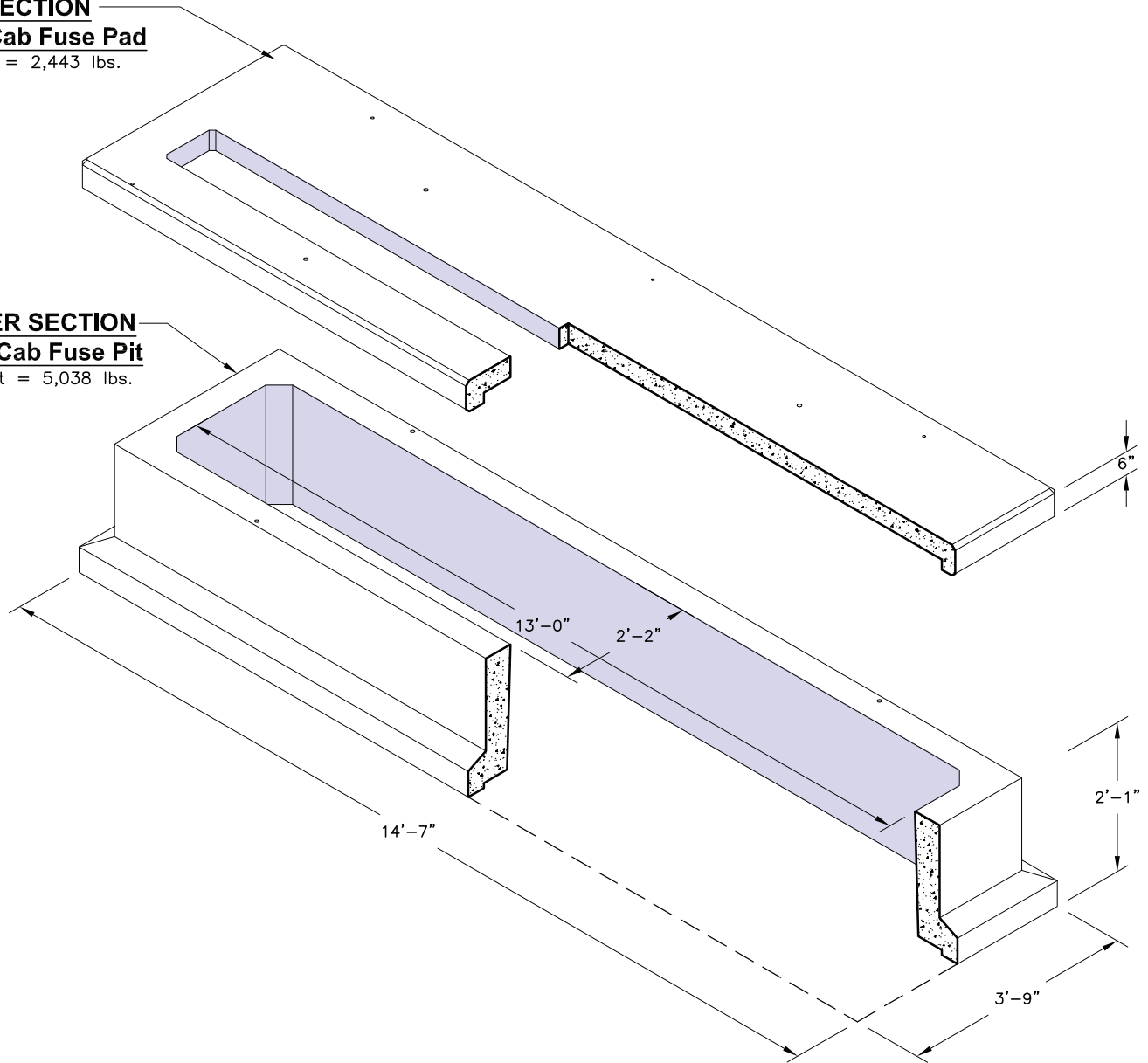

**NOTE:**  
 Stack Height NOT to Exceed (2) Pit Sections  
 \*Designed for Installation at Grade with Cabinet Loading

<b>Electrical Pit &amp; Pad Components</b>		
Description	Item Code	Weight
466 Pad	1824500	2,443 lbs.
466 Pit	1801400	5,038 lbs.

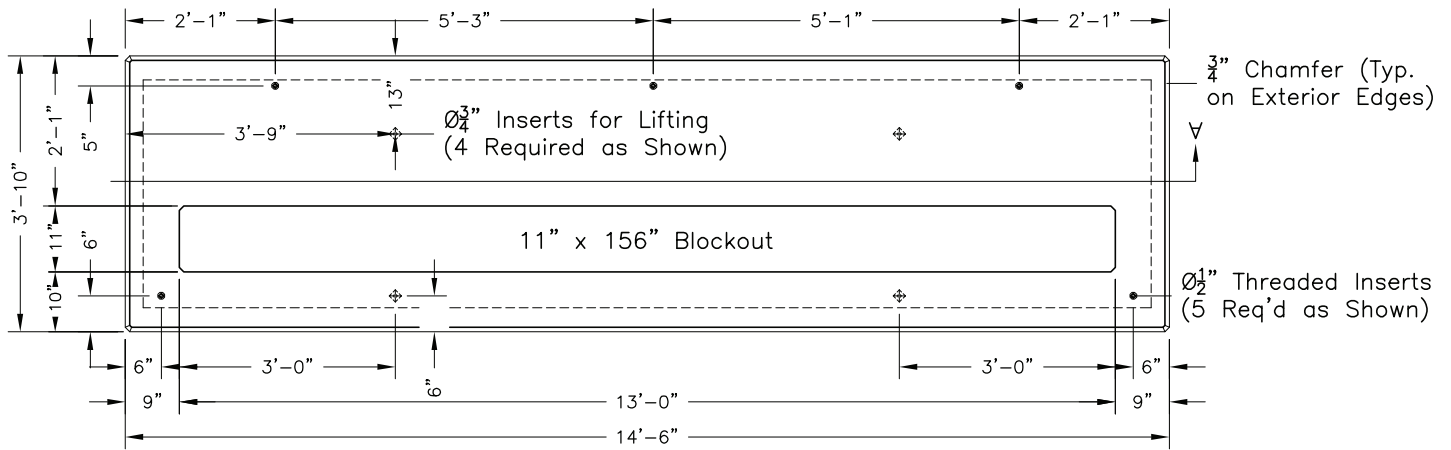
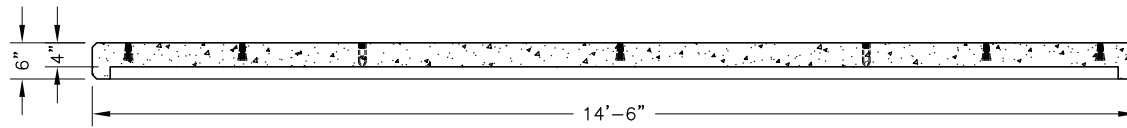
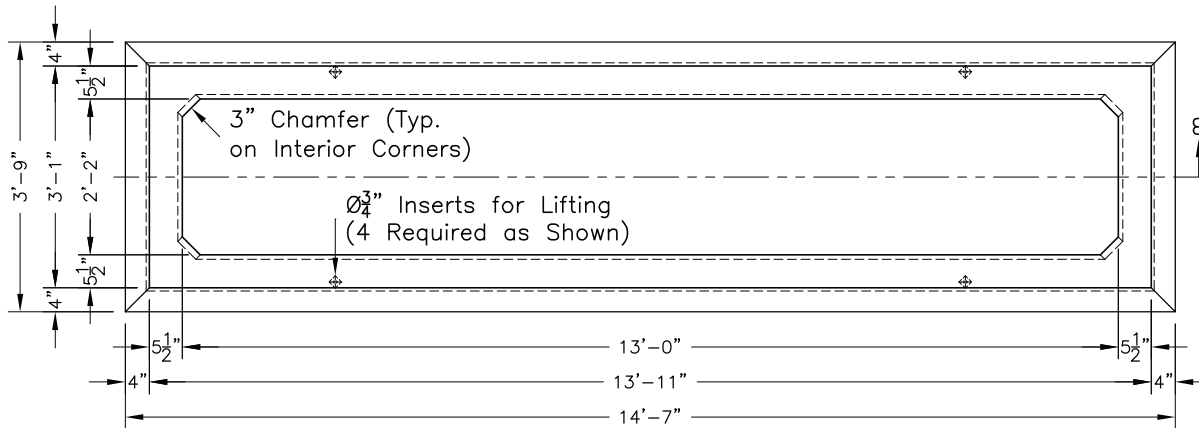
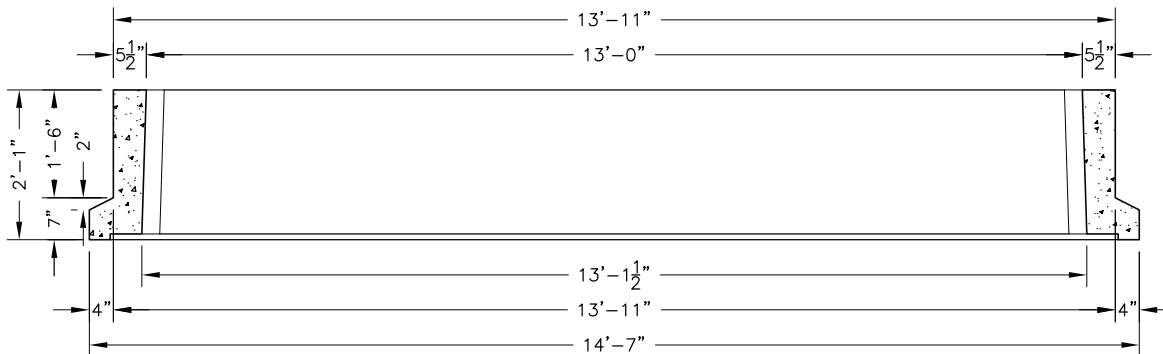
**Pad Plan View**

**Pad Section A**

**Pit Plan View**

**Pit Section B**