

Uv Co 3030P Galvanized
Hatch Diamond
Plated (2 Req'd)

LID SECTION

Weight = 7,049 lbs.

2-332-P Galvanized
Hatch Diamond Plated,
Hinged, & Lockable

If A Riser Is Req'd
The Base Is Poured
With A Shiplap Joint

BASE SECTION

Weight = 27,511 lbs.

12" Dia. Inlet Pipe
Supplied By
Contractor

Sludge Weir
Weight = 724 lbs.

Oil Weir
Weight = 1,030 lbs.

Outlet Weir
Weight = 956 lbs.

12" Dia. Outlet Pipe
Supplied By
Contractor

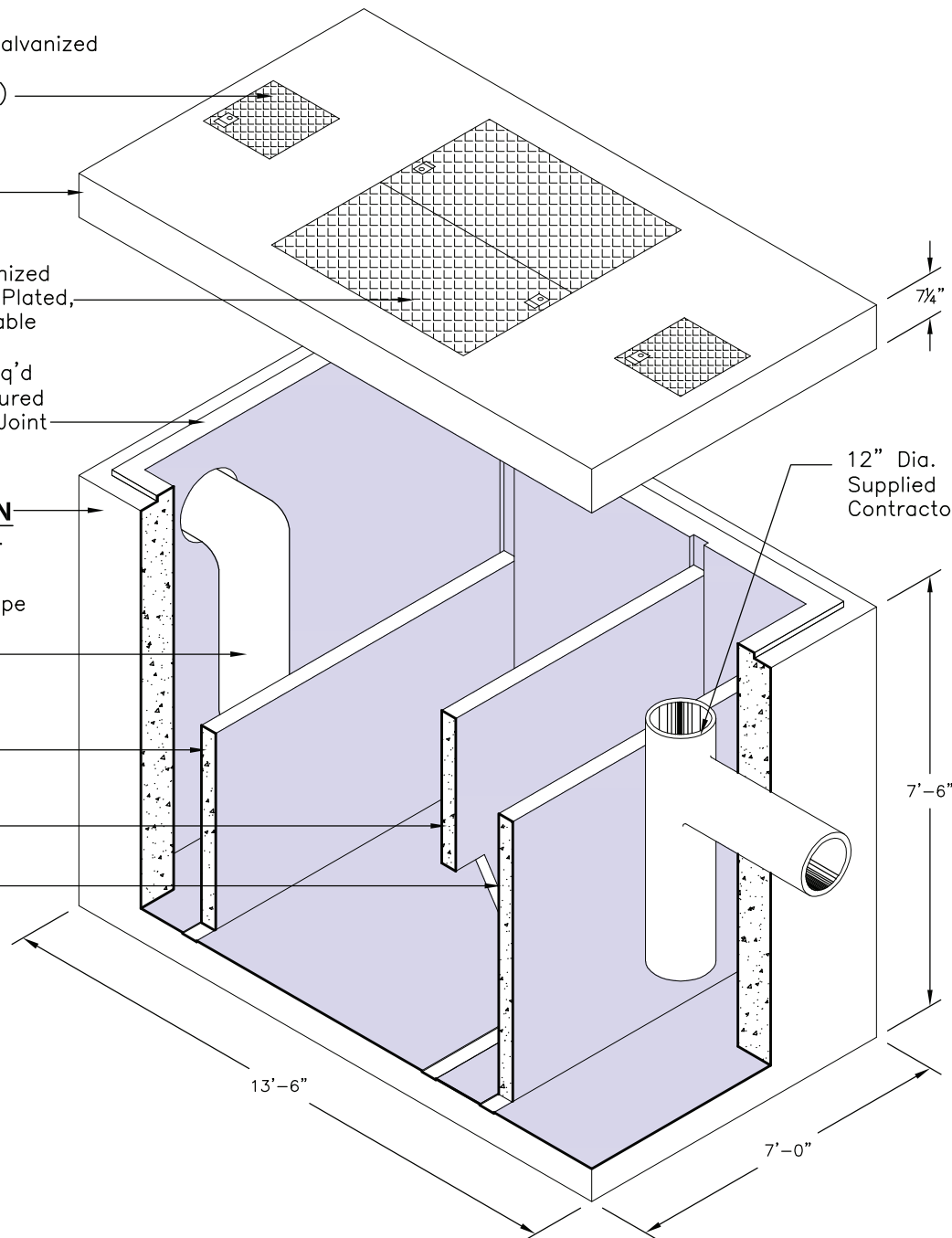

Design Information

Influent Conditions

- 45° Water Temperature
- 0.85 Oil Specific Gravity
- 100 PPM Influent Concentration

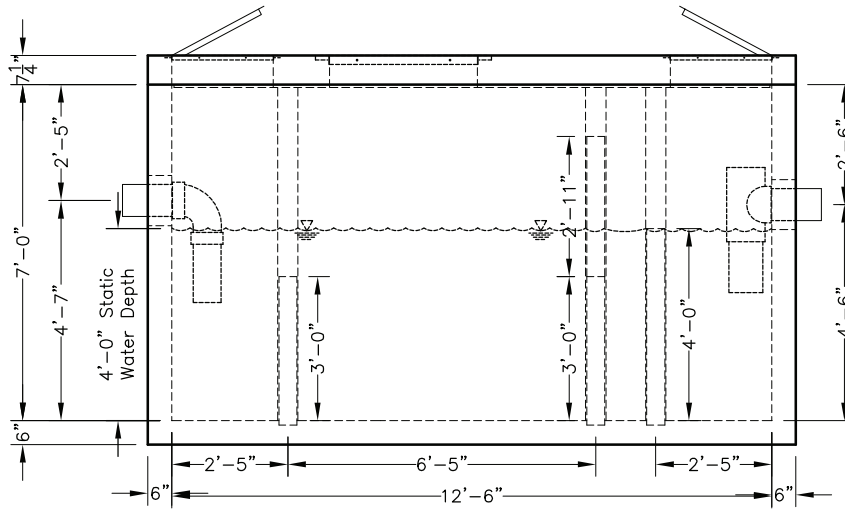
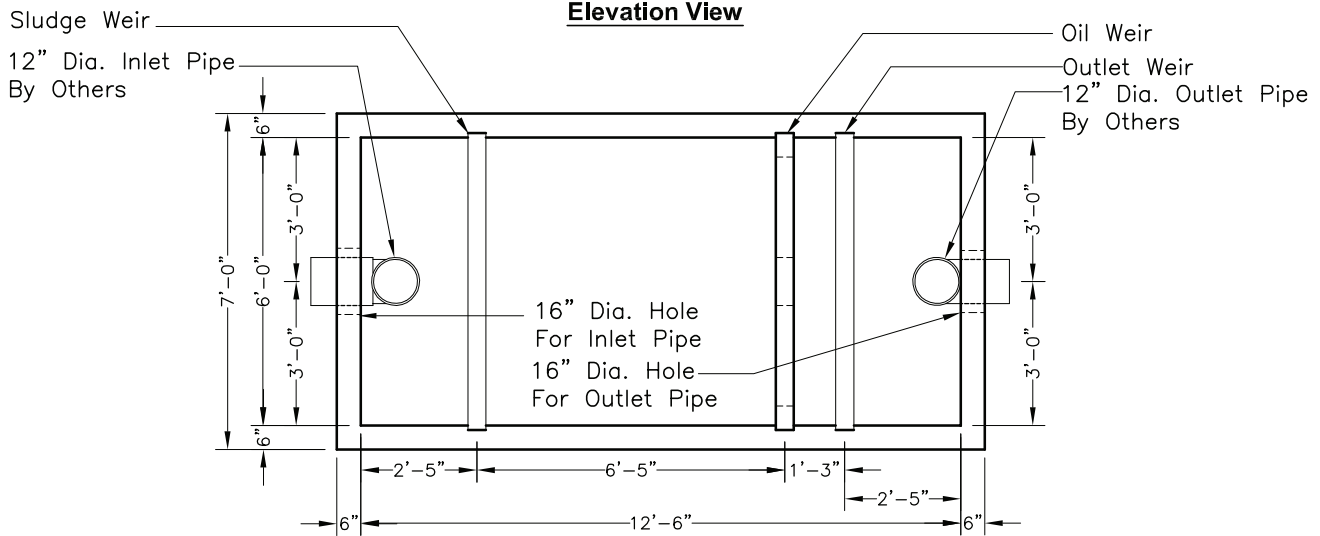
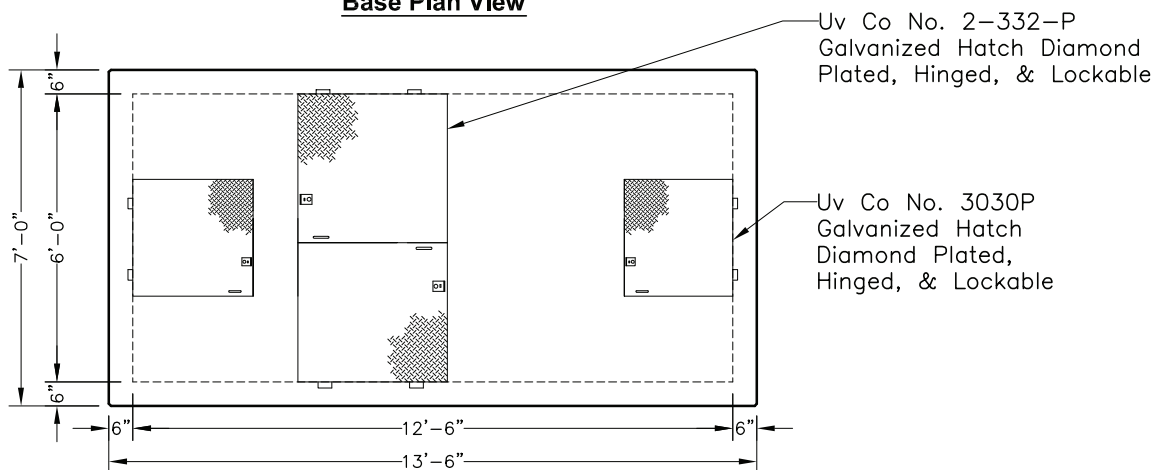
Elevation View

Base Plan View

Lid Plan View