

REV	DESCRIPTION	BY	DATE
A	CHANGED CURVED HOOKS TO STRAIGHT HOOKS	AT	3/18/16
B	NCS UPDATES	CP	6/26/17

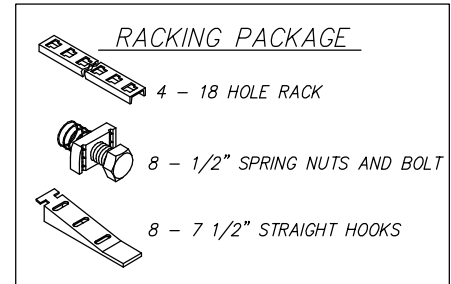
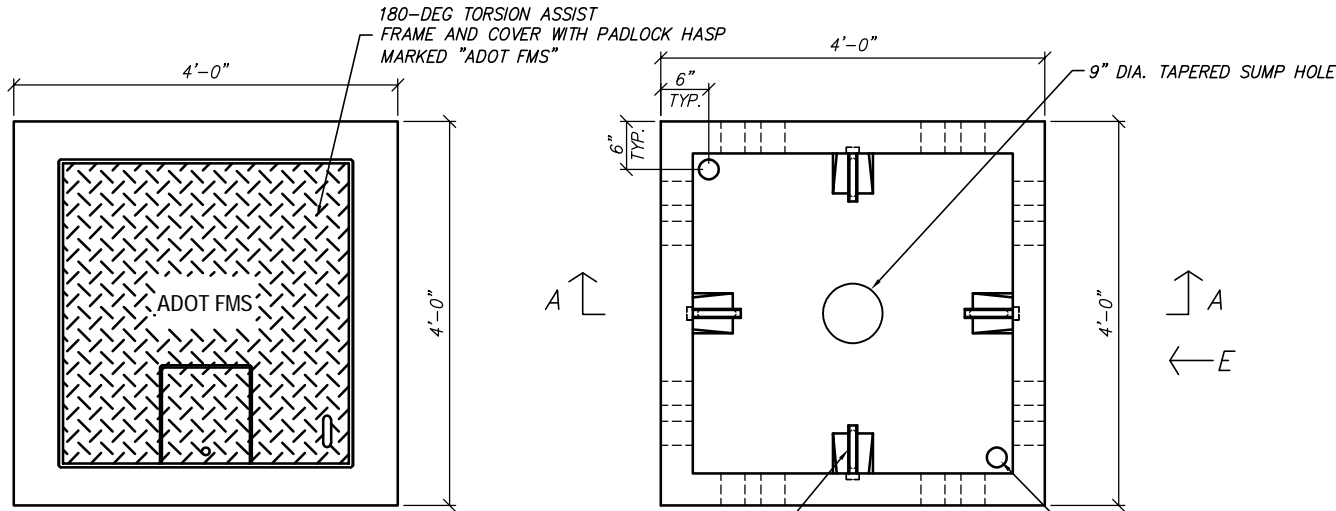

**PLAN VIEW WITH COVER**  
SCALE: 1/2" = 1'-0"

**PLAN VIEW**  
SCALE: 1/2" = 1'-0"

**STRUCTURAL NOTES**

1. CONCRETE: 28 DAY COMPRESSIVE STRENGTH  $f_c = 5,000$  psi
2. REBAR: ASTM A-615 GRADE 60
3. MESH: ASTM A-1064 GRADE 65
4. DESIGN: ACI 318-11 BUILDING CODE  
ASTM C-857 "MINIMUM STRUCTURAL DESIGN  
LOADING FOR UNDERGROUND PRECAST  
CONCRETE UTILITY STRUCTURES"
5. LOADS: HS20 WHEEL LOADING IN OFF-STREET LOCATIONS WHERE  
NOT SUBJECTED TO HIGH DENSITY TRAFFIC  
80 PSF LATERAL LIVE LOAD SURCHARGE - UP TO 8'-0" DEPTH  
SOIL: 40 PCF LATERAL SOIL PRESSURE ABOVE WATER TABLE  
80 PCF LATERAL SOIL PRESSURE BELOW WATER TABLE  
120 PCF SOIL DENSITY
6. SOIL COVER: NONE
7. WATER TABLE: 5'-0" BELOW GRADE

**GENERAL NOTES**

1. ALL JOINTS SHALL BE SEALED USING CONSEAL CS-101 BUTYL RUBBER ROPE.

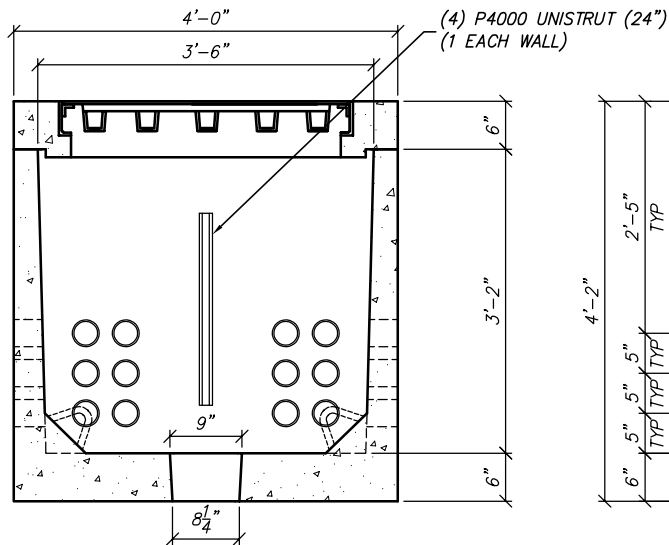

**SECTION VIEW A-A**  
SCALE: 1/2" = 1'-0"

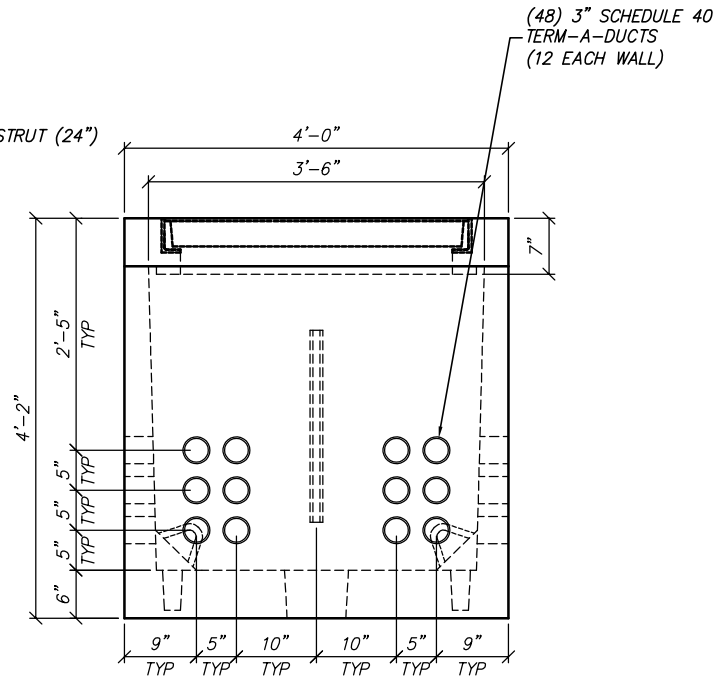

**VIEW E**  
SCALE: 1/2" = 1'-0"



411 E. FRYE RD. CHANDLER, AZ 85225  
PHONE: (480) 963-2878

THIS DOCUMENT IS THE PROPERTY OF OLDCASTLE PRECAST, INC. IT IS CONFIDENTIAL, SUBMITTED FOR REFERENCE PURPOSES ONLY, AND SHALL NOT BE USED IN ANY WAY INJURIOUS TO THE INTERESTS OF, OR WITHOUT THE WRITTEN PERMISSION OF OLDCASTLE PRECAST, INC. COPYRIGHT ©2017 OLDCASTLE PRECAST, INC. ALL RIGHTS RESERVED

**ADOT #9 PULL BOX**

ADOT FMS

CUSTOMER  
**STANDARD**

DATE	SALES	DRAWN	ENGINEER	CHECKED	SALES ORDER
6/27/17		FS			---

DRAWING NUMBER	REVISION	SHEET
H17L5-1	REV DATE	1 OF 1