

NOTES:

1. INLET & OUTLET ARE IDENTIFIED.
2. TANK IS MARKED 2,000 GALLON.
3. INLET & OUTLET BAFFLES WILL ACCEPT A NOM. 4" SCH. 40 PVC PIPE.
4. 1 1/2" x 3'-6" STRIPS OF RAM-NEK USED FOR SEALING JOINTS.
5. OPENINGS MAY BE SIZED & LOCATED AS SPECIFIED WITHIN STRUCTURAL LIMITATIONS.
6. BAFFLES ARE TO BE INSTALLED BY OTHERS.
7. METRIC EQUIVALENTS (SHOWN IN PARENTHESIS) ARE ROUNDED TO NEAREST 5mm, 5kg OR 5L.
8. PLACE OLDCASTLE LOGO ON OUTSIDE OF TANK.
9. .8T CABLE LOOP, PLACED IN ACCESS LIDS FOR LIFTING
10. DESIGNED FOR 8'-0" MAX BURY.



2240 S. Yellowstone Hwy, Idaho Falls, Idaho 83402
 Phone: 208-522-6150 Fax: 208-522-9701

Grease Trap

FILE NAME: 230TBGI05

ISSUE DATE: 1/2011

www.oldcastleprecast.com

2000 Gal 5' X 10'
(Hs-20 Traffic Rated)

ISO View

Copyright © 2011

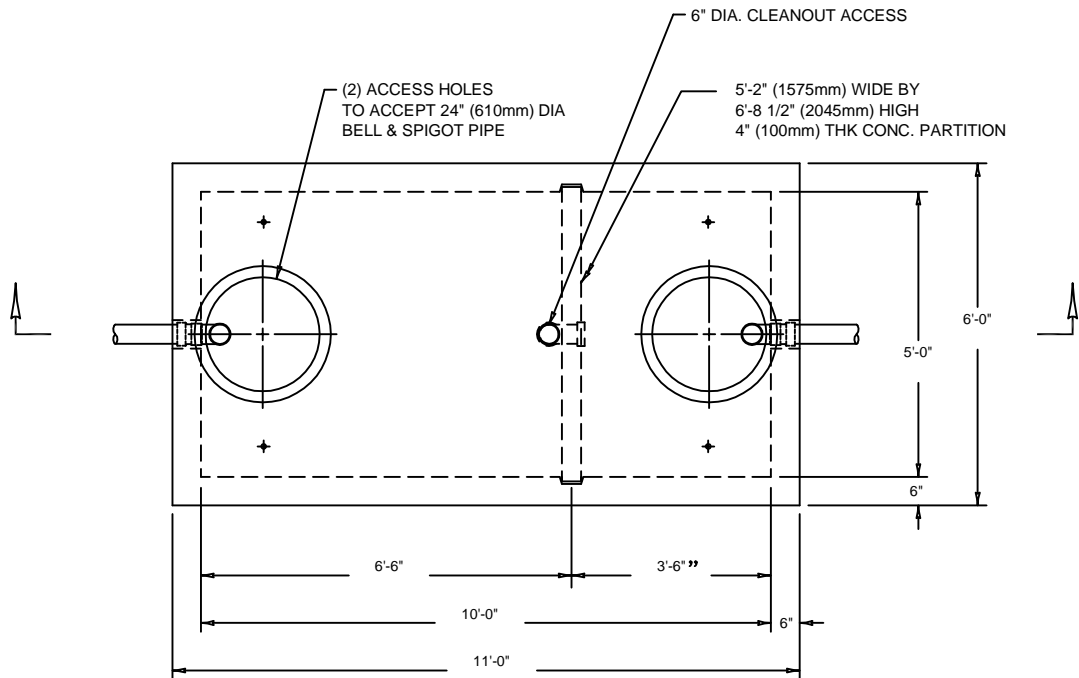

TRAFFIC RATED TANK - TOP THICKNESS AND REINFORCING MAY VARY PER DESIGN REQUIREMENTS

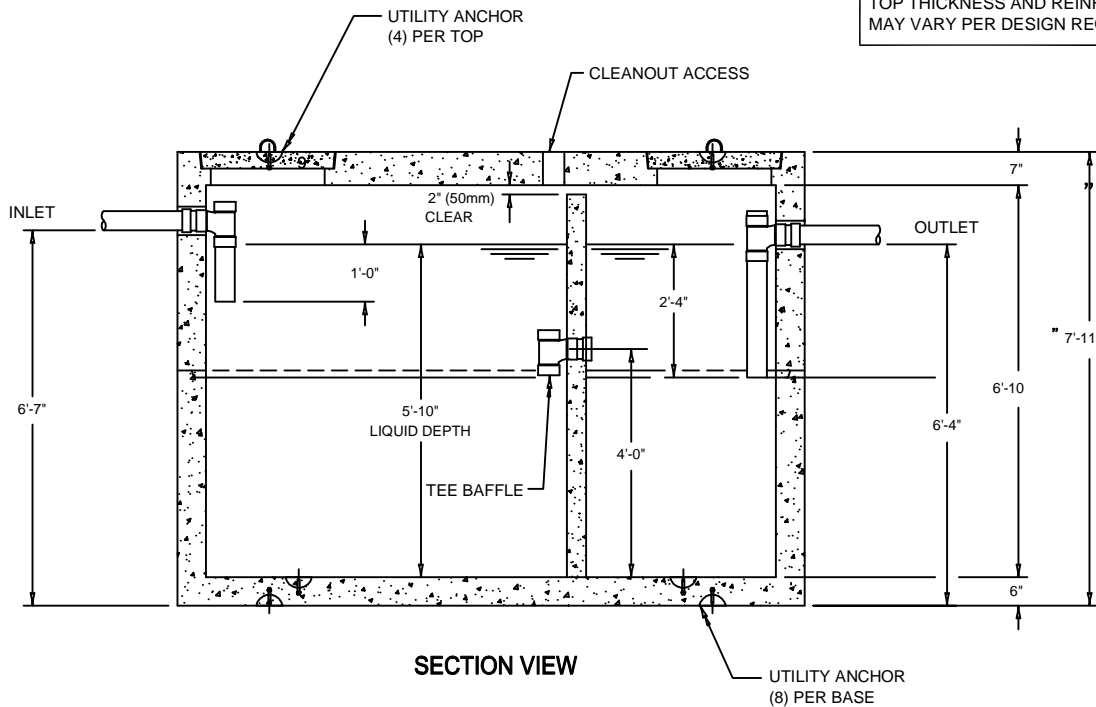

2240 S. Yellowstone Hwy, Idaho Falls, Idaho 83402
Phone: 208-522-6150 Fax: 208-522-9701

Grease Trap

FILE NAME: 230TBGI05

ISSUE DATE: 1/2011

www.oldcastleprecast.com

2000 Gal 5' X 10'
(Hs-20 Traffic Rated)

Copyright © 2011