

TRAFFIC RATED TANK -
TOP THICKNESS AND REINFORCING
MAY VARY PER DESIGN REQUIREMENTS

NOTES:

1. INLET & OUTLET ARE IDENTIFIED.
2. TANK IS MARKED 4,000 GALLON.
3. INLET & OUTLET Baffles WILL ACCEPT A NOM. 4" SCH. 40 PVC PIPE.
4. 1 1/2" x 3'-6" STRIPS OF RAM-NEK USED FOR SEALING JOINTS.
5. OPENINGS MAY BE SIZED & LOCATED AS SPECIFIED WITHIN STRUCTURAL LIMITATIONS.
6. Baffles ARE TO BE INSTALLED BY OTHERS.
7. METRIC EQUIVALENTS (SHOWN IN PARENTHESIS) ARE ROUNDED TO NEAREST 5mm, 5kg OR 5L.
8. PLACE OLDCASTLE LOGO ON OUTSIDE OF TANK.
9. .8T CABLE LOOP, PLACED IN ACCESS LIDS FOR LIFTING
10. DESIGNED FOR 8'-0" MAX. BURY.



2240 S. Yellowstone Hwy, Idaho Falls, Idaho 83402
Phone: 208-522-6150 Fax: 208-522-9701

Grease Trap

FILE NAME: 230TBG107

ISSUE DATE: 1/2011

www.oldcastleprecast.com

4000 Gal 6' X 14'
(Hs-20 Traffic Rated)

ISO View

Copyright © 2011

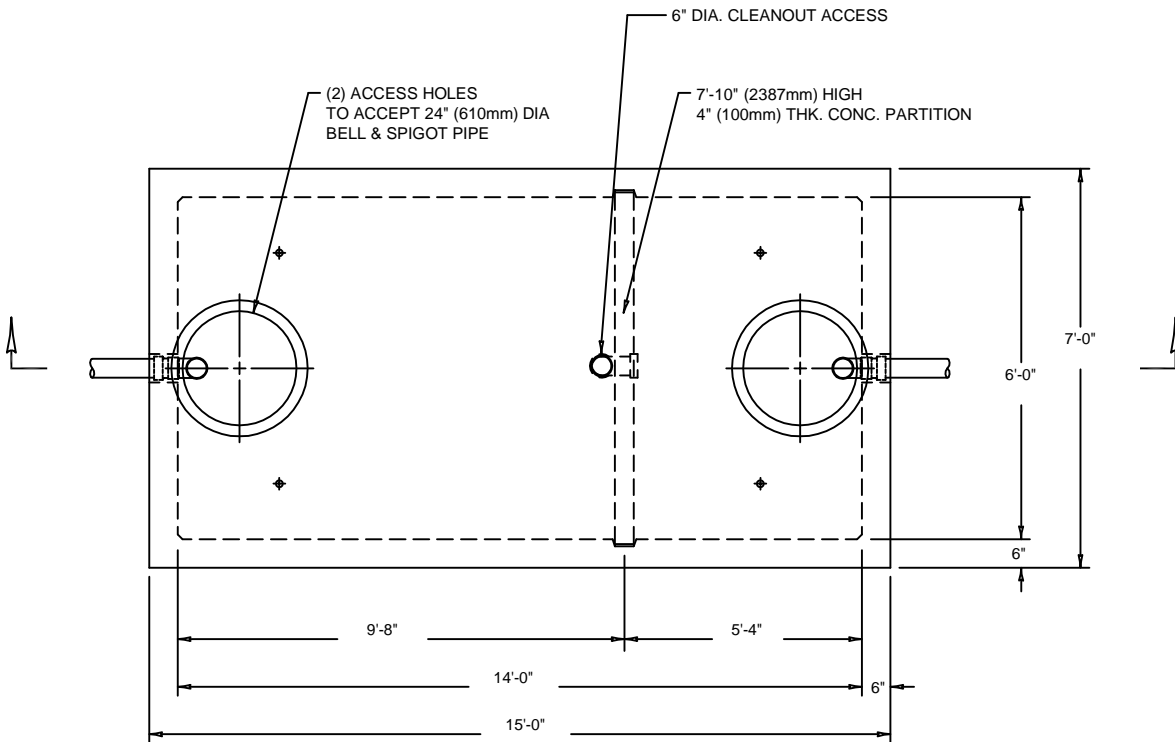

PLAN VIEW

TRAFFIC RATED TANK - TOP THICKNESS AND REINFORCING MAY VARY PER DESIGN REQUIREMENTS

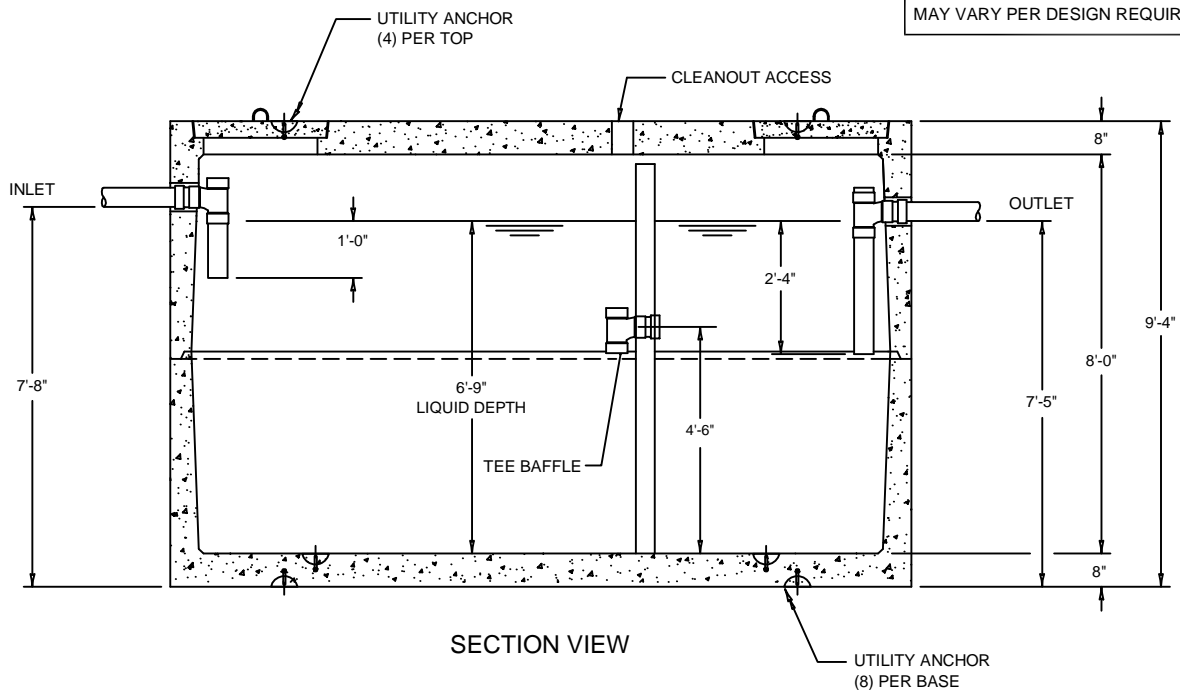

SECTION VIEW



2240 S. Yellowstone Hwy, Idaho Falls, Idaho 83402
 Phone: 208-522-6150 Fax: 208-522-9701

Grease Trap

FILE NAME: 230TBG107

ISSUE DATE: 1/2011

www.oldcastleprecast.com

4000 Gal 6' X 14'
 (Hs-20 Traffic Rated)

Copyright © 2011