

2240 S. Yellowstone Hwy, Idaho Falls, Idaho 83402
 Phone: 208-522-6150 Fax: 208-522-9701

Box Culvert

FILE NAME: 230DBSBOXCULV2

ISSUE DATE: 1/2011

www.oldcastleprecast.com

Split Box Culvert
3' x 3' thru 12' x 12'
AASHTO HS-20 Loading

Copyright © 2010

NOTE:
THE SMALLEST SIZE IS A 3'-0" X 3'-0"
BOX, USING PRECISE FORMING.

NOTE:
LAY LENGTHS & WALL & LID
THICKNESS WILL BE DETERMINE BY
LOAD RATINGS & OVERALL WEIGHT.

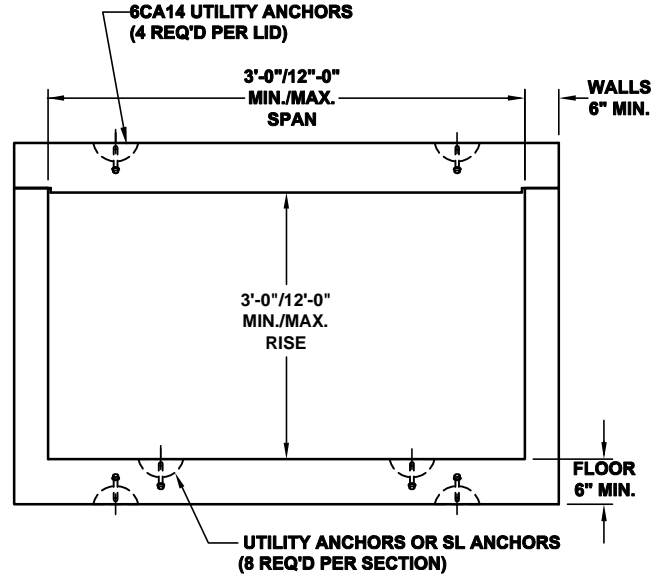

PROFILE VIEW

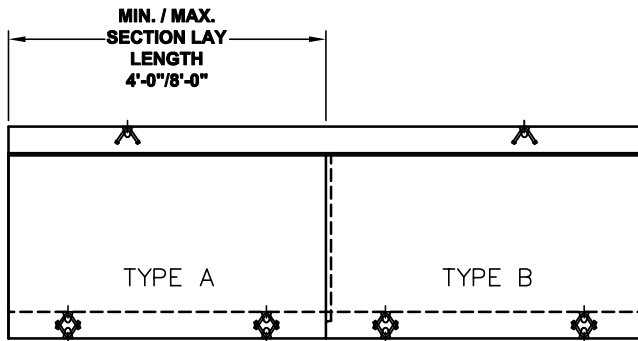

PLAN VIEW

NOTE:
TWO DIFF. JOINTS ARE AVAILABLE
FOR 6" & 8" WALLS

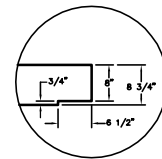

TYP. LID JOINT DETAIL

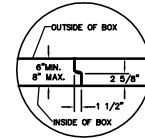

JOINT DETAIL FOR WALLS 6" AND 8" THICK

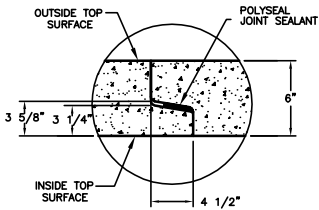

JOINT DETAIL FOR WALLS 6" AND 8" THICK

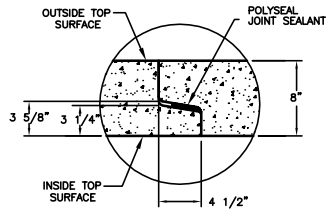

JOINT DETAIL FOR WALLS 10" AND 12"

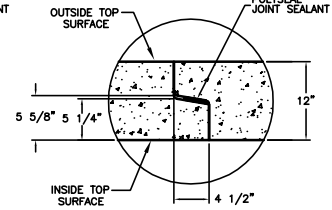
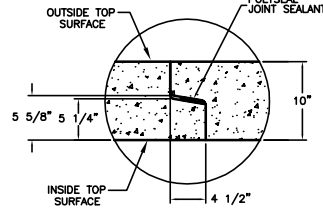

2240 S. Yellowstone Hwy, Idaho Falls, Idaho 83402
Phone: 208-522-6150 Fax: 208-522-9701

Box Culvert

FILE NAME: 230DBSBOXCULV2

ISSUE DATE: 1/2011

www.oldcastleprecast.com

Split Box Culvert
3' x 3' thru 12' x 12'
AASHTO HS-20 Loading

Copyright © 2010