

WEIGHTS	
SECTION	WEIGHT
TOP SLAB	12,200 LBS
BASE SECTION	18,900 LBS
TOTAL	31,100 LBS

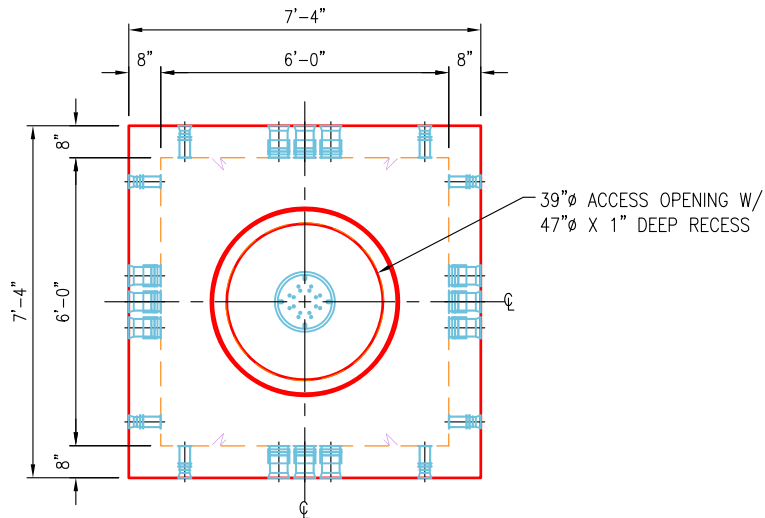

PLAN VIEW
SCALE: 1/4" = 1'-0"

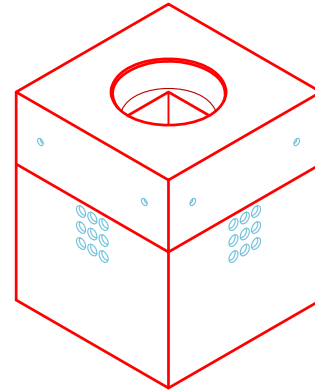

ISO VIEW
SCALE: 1/8" = 1'-0"

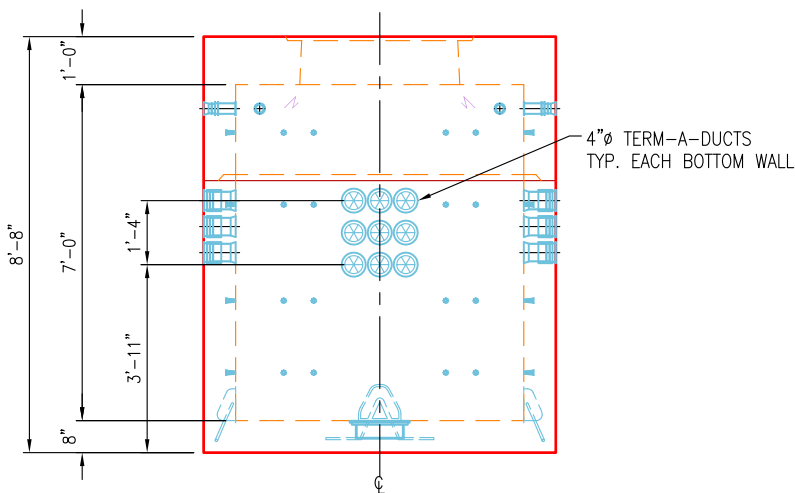

SIDE VIEW
SCALE: 1/4" = 1'-0"

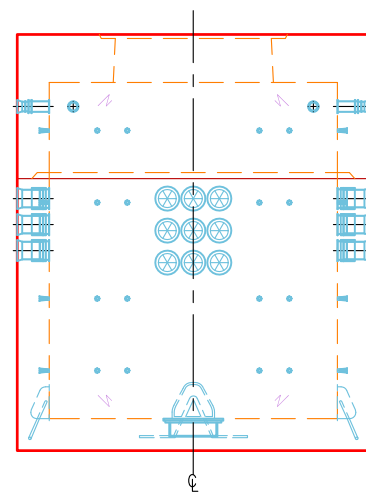

END VIEW
SCALE: 1/4" = 1'-0"

SPECIFICATIONS:

- Concrete minimum compression strength:
F'c=5,000 PSI @ 28 days.
- Reinforcing steel: ASTM A615, Fy=60,000 PSI

ITEMS ARE SUBJECT TO CHANGE WITHOUT NOTICE.