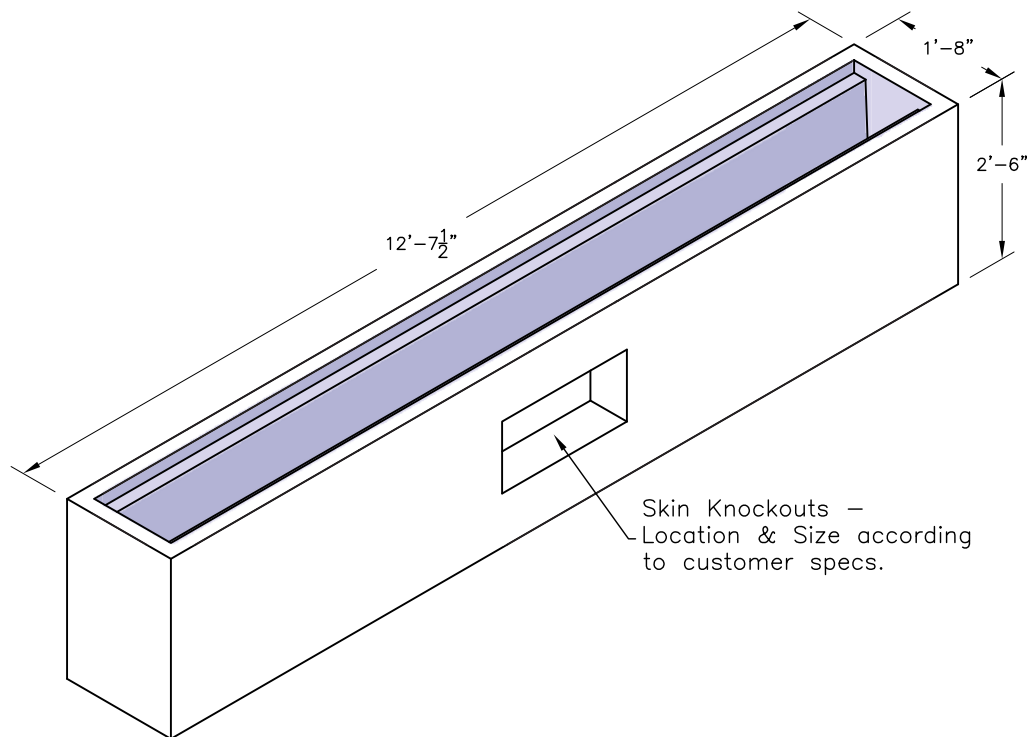

**Trench Drain****SPECIFICATIONS:**

1. Post and panel concrete to be 4,000 psi.
2. Steel Reinforcement: ASTM A-615, Grade 60, ASTM A-185.
3. Approx. weight = 475 lbs. per ft.