

Area Drain Type 2

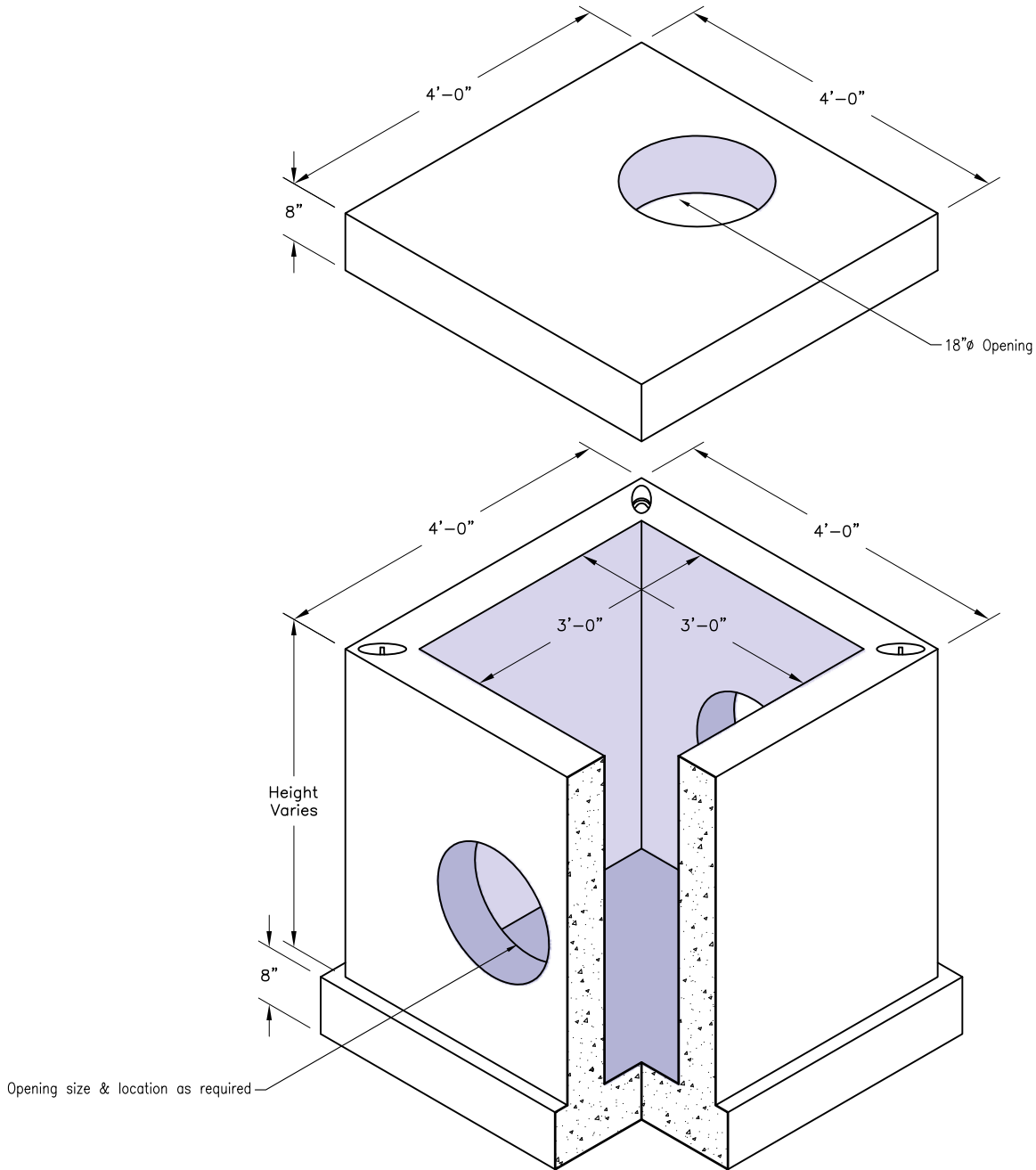

GENERAL NOTES:

1. Concrete: 28 Day Compressive Strength $f'c = 4,000\text{psi}$.
2. Steel Reinforcement: ASTM A-615, Grade 60.
3. Manhole meets ASTM C-478 specifications.