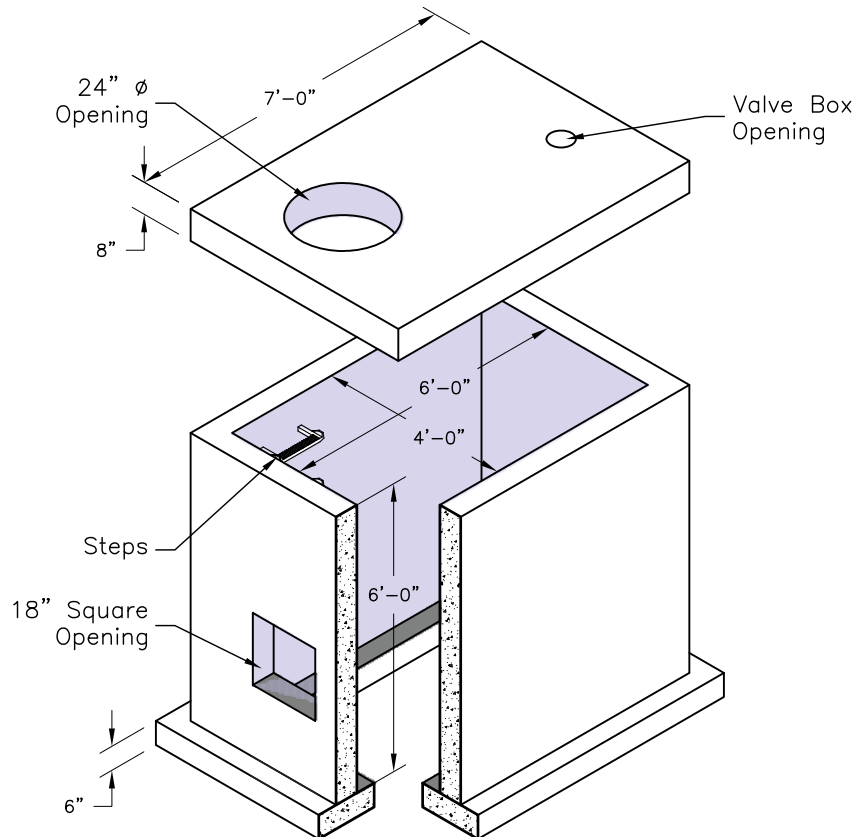

DT-200 Roadway WMV**SPECIFICATIONS:**

1. Concrete: 28 day compressive strength $f'c = 4,000$ psi.
2. Steel Reinforcement: ASTM A-615, Grade 60.
3. Bottom and top slabs are detached.
4. Reinforcement for H-20 wheel loading with 18" ground cover.