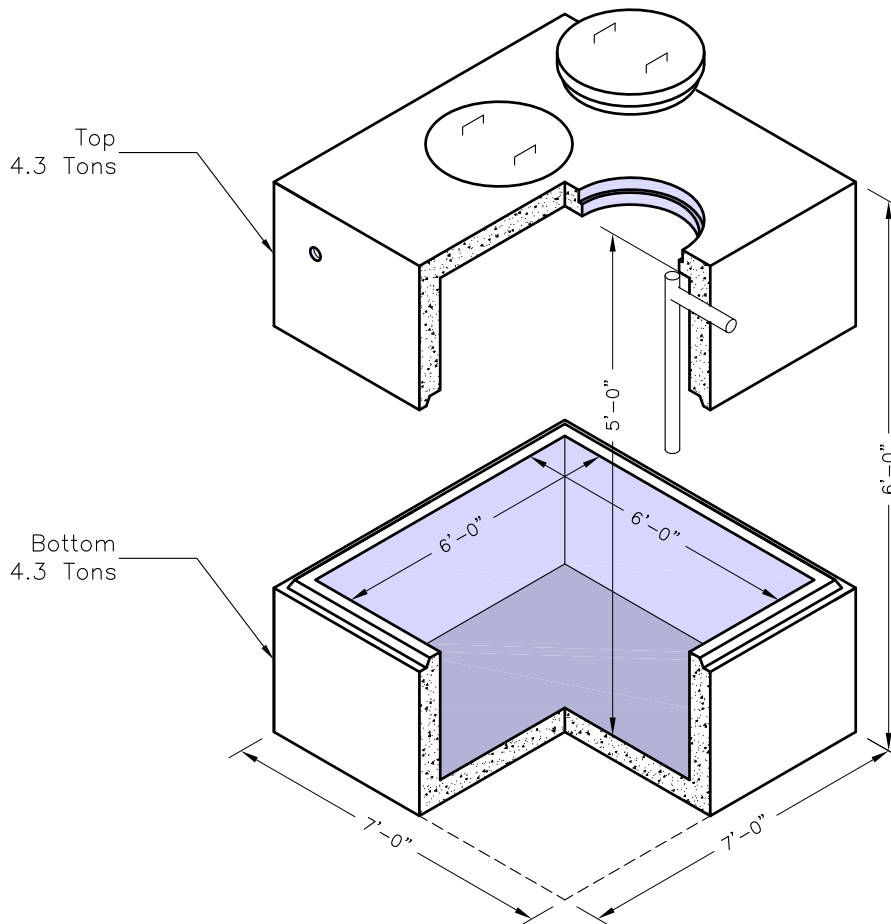

Grease Interceptor

GENERAL NOTES:

1. Concrete: 28 Day Compressive Strength $f'_c = 5,000$ psi
2. Steel Reinforcement: ASTM A-615 Grade 60
3. Cover to Steel - 1" Minimum
4. Vaults are Designed to Meet ASTM C858 and ACI 318 with AASHTO HS-20 Loading
5. Earth Cover - 0 to 1 Feet
6. Construction Joint Sealed with 1" Dia. Butyl Rubber or Equivalent
7. Stock Structure has Inserts Cast into the Inside Surfaces in a Stock Pattern. Pattern Available Upon Request.