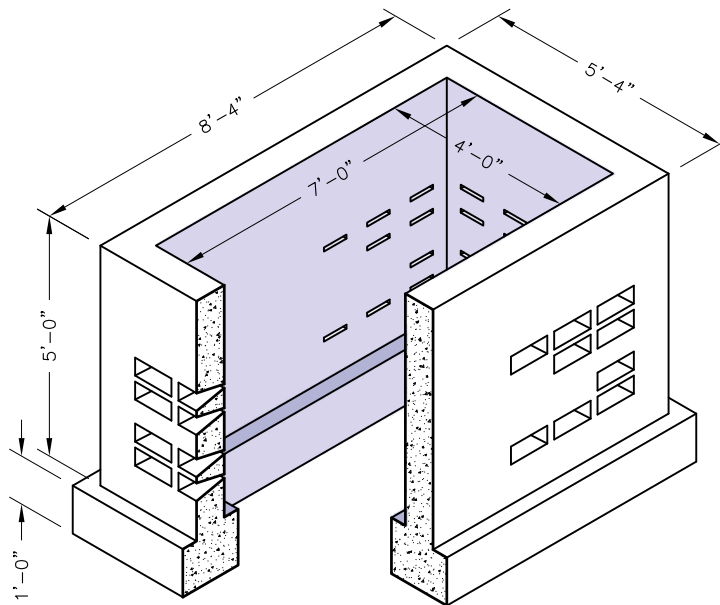

Leaching Basin

Weight: 12,500 lbs.

**SPECIFICATIONS:**

1. Concrete: 28 Day Compressive Strength $f'c = 4,000\text{psi}$.
2. This drawing shows only size and type of structures approved by Suffolk County.
3. Approx. weight = 12,500 lbs.