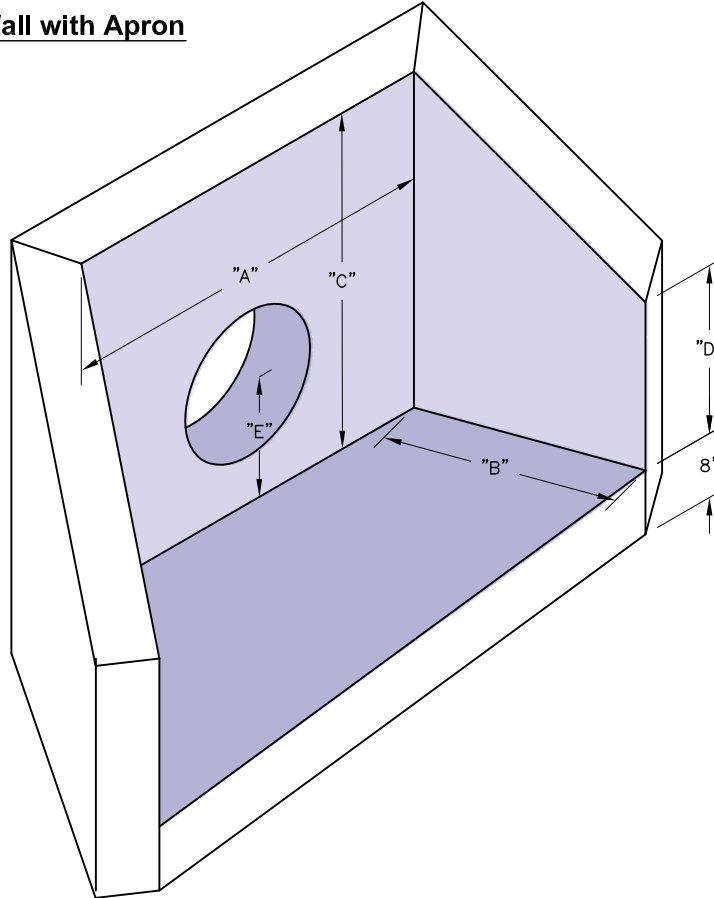

Wing Wall with Apron

SPECIFICATIONS:

1. Concrete: 28 Day Compressive Strength $f'c = 4,000$ psi.
2. Steel reinforcement: ASTM A-615, Grade 60, ASTM A-185.
3. All exposed edges to have 1" bevel.
4. Apron by contractor in field.
5. Special sizes not listed can be manufactured upon request.

WING WALL WITH APRON

PIPE ϕ	A	B	C	D	E	WEIGHT/LBS.
12"	36"	30"	36"	18"	12"	3845
15"	48"	30"	42"	21"	37-1/2"	4760
18"	48"	30"	42"	21"	15"	4760
24"	60"	36"	48"	24"	18"	6090
30"	72"	36"	54"	27"	21"	7475
36"	78"	48"	60"	30"	24"	9945
42"	84"	48"	72"	36"	30"	11325