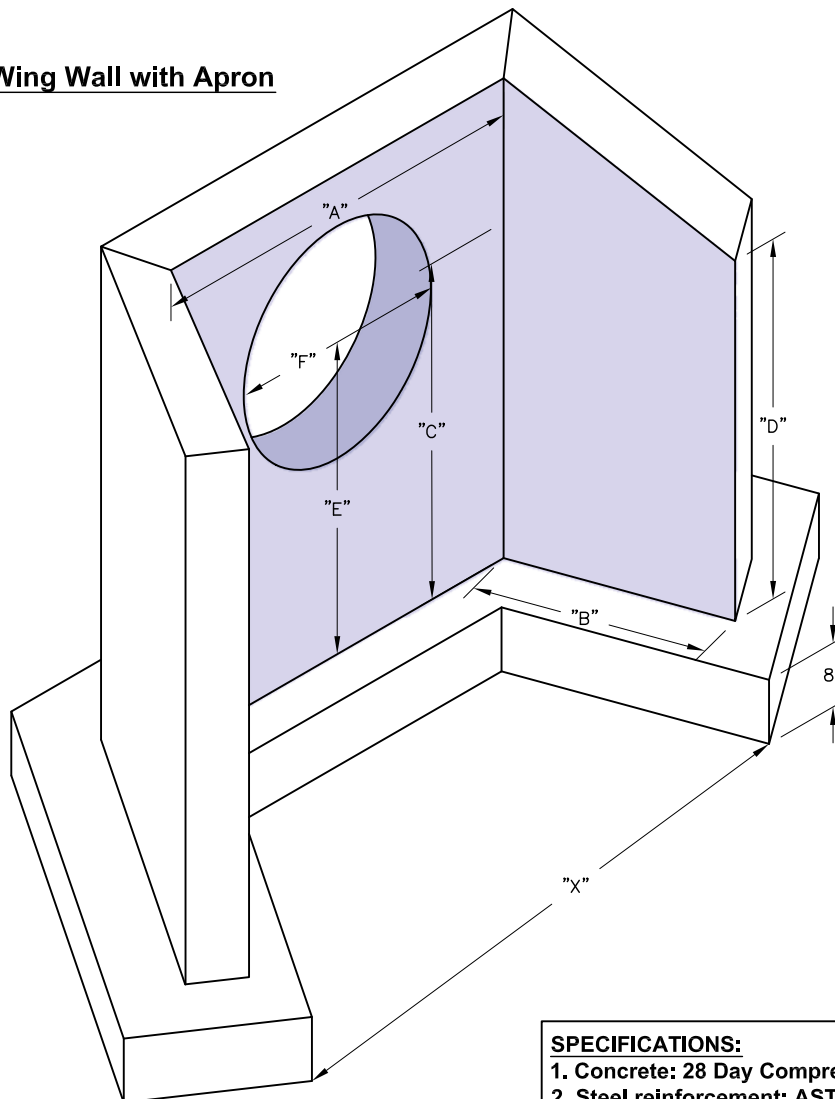

**Wing Wall with Apron**

**SPECIFICATIONS:**

1. Concrete: 28 Day Compressive Strength  $f_c = 4,000$  psi.
2. Steel reinforcement: ASTM A-615, Grade 60, ASTM A-185.
3. All exposed edges to have 1" bevel.
4. Apron by contractor in field.
5. Special sizes not listed can be manufactured upon request.

SPECIFICATIONS								
PIPE $\phi$	A	B	C	D	E	X (REF)	WEIGHT/LBS.	F
12"	36"	30"	54"	40"	36"	6'-6-1/2"	5445	18"
15"	48"	30"	60"	45"	37-1/2"	7'-6-1/2"	6400	24"
18"	48"	30"	60"	45"	39"	7'-6-1/2"	6400	28"
24"	60"	36"	64"	48"	42"	9'-3"	7250	36"
30"	72"	36"	72"	54"	45"	10'-3"	9276	42"
36"	78"	48"	78"	60"	48"	12'-2"	11623	48"
42"	84"	48"	96"	66"	54"	12'-8"	12402	60"