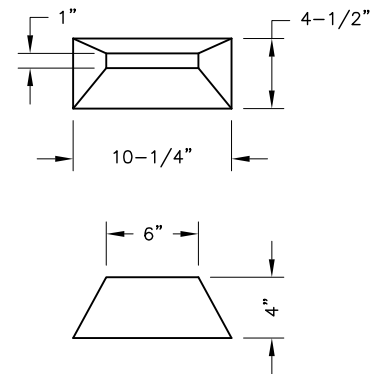
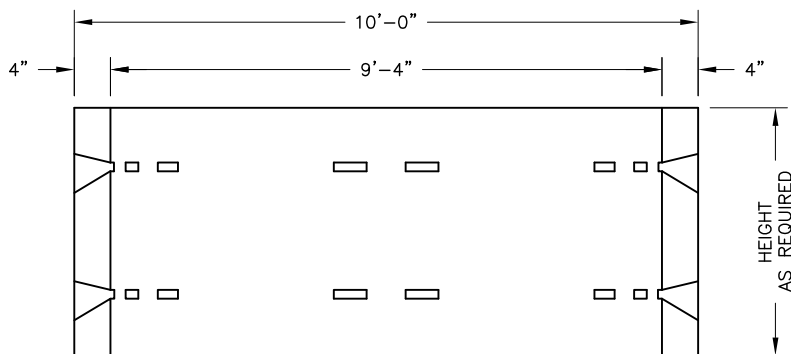

PLAN

LEACHING BLOCK DETAIL

SECTION A-A

SPECIFICATIONS			
RING HEIGHTS	VOLUME C.F.	VOLUME GAL.	APPROX. WEIGHT/LBS.
3'-0"	205	1536	4600
4'-0"	273	2048	6100
5'-0"	342	2559	7600

GENERAL NOTES:

1. Concrete: 28 Day Compressive Strength $f'c = 4,000\text{psi}$.
2. Steel Reinforcement: ASTM A-615, Grade 60, ASTM A-185.