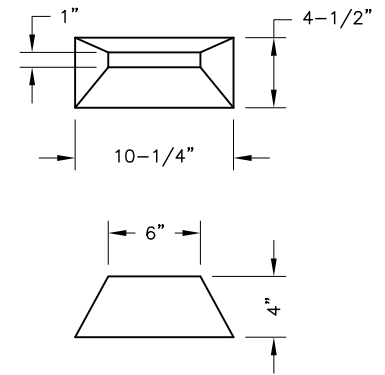
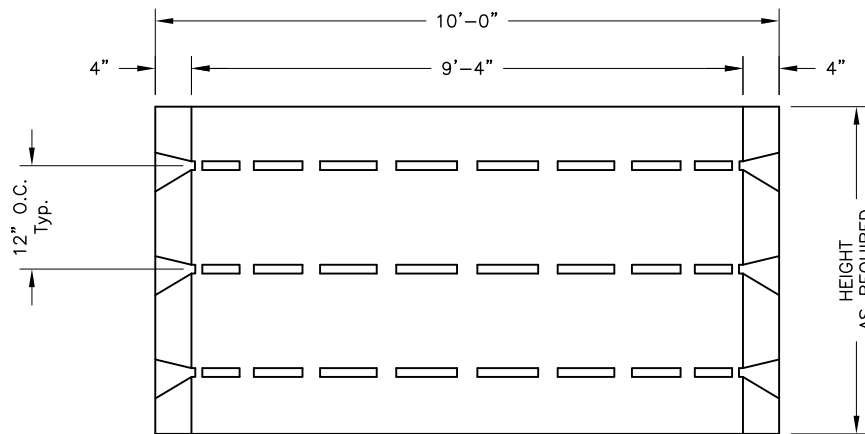

**PLAN**

**LEACHING BLOCK DETAIL**

**SECTION A-A**

SPECIFICATIONS				
RING HEIGHTS	LEACHING AREA	VOLUME C.F.	VOLUME GAL.	APPROX. WEIGHT/LBS.
3'-0"	94 S.F.	205	1536	4300
4'-0"	126 S.F.	273	2048	5800
5'-0"	157 S.F.	342	2559	7300

**GENERAL NOTES:**

1. Concrete: 28 Day Compressive Strength  $f'_c = 4,000\text{psi}$ .
2. Steel Reinforcement: ASTM A-615, Grade 60, ASTM A-185.