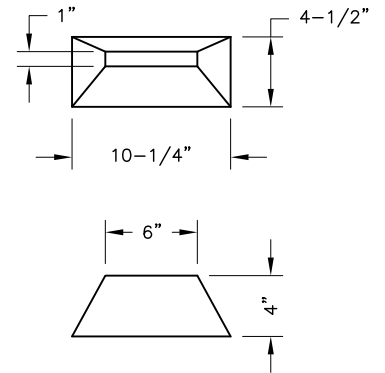
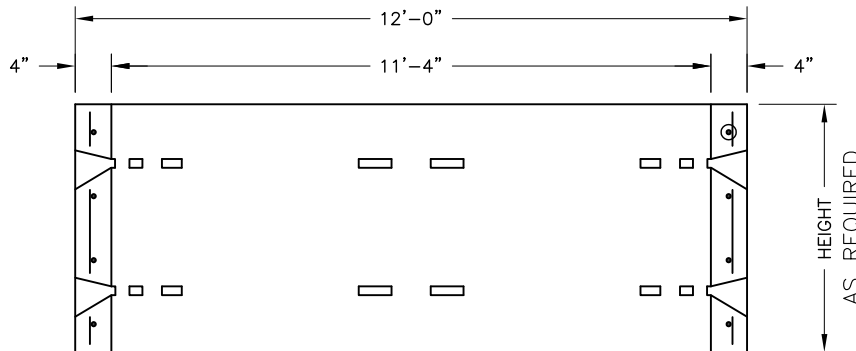

**PLAN**

**LEACHING BLOCK DETAIL**

**SECTION A-A**

| SPECIFICATIONS |             |             |                     |
|----------------|-------------|-------------|---------------------|
| RING HEIGHTS   | VOLUME C.F. | VOLUME GAL. | APPROX. WEIGHT/LBS. |
| 3'-0"          | 302         | 2264        | 5500                |
| 4'-0"          | 403         | 3023        | 7300                |
| 5'-0"          | 505         | 3788        | 9200                |

**GENERAL NOTES:**

1. Concrete: 28 Day Compressive Strength  $f'_c = 4,000\text{psi}$ .
2. Steel Reinforcement: ASTM A-615, Grade 60, ASTM A-185.