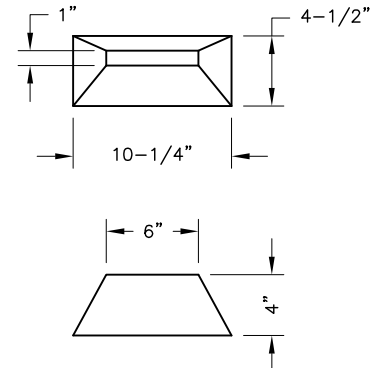
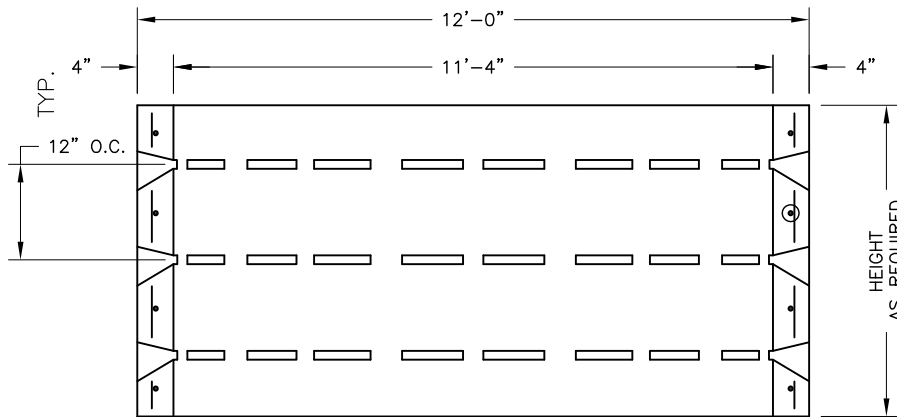

**PLAN**

**LEACHING BLOCK DETAIL**

**SECTION A-A**

SPECIFICATIONS				
RING HEIGHTS	LEACHING AREA	VOLUME C.F.	VOLUME GAL.	APPROX. WEIGHT/LBS.
3'-0"	111 S.F.	302	2264	4875
4'-0"	150 S.F.	403	3023	6500
5'-0"	189 S.F.	505	3788	8125

**GENERAL NOTES:**

1. Concrete: 28 Day Compressive Strength  $f'_c = 4,000\text{psi}$ .
2. Steel Reinforcement: ASTM A-615, Grade 60, ASTM A-185.