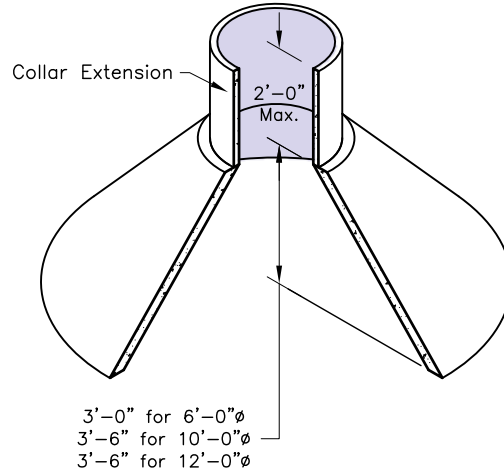
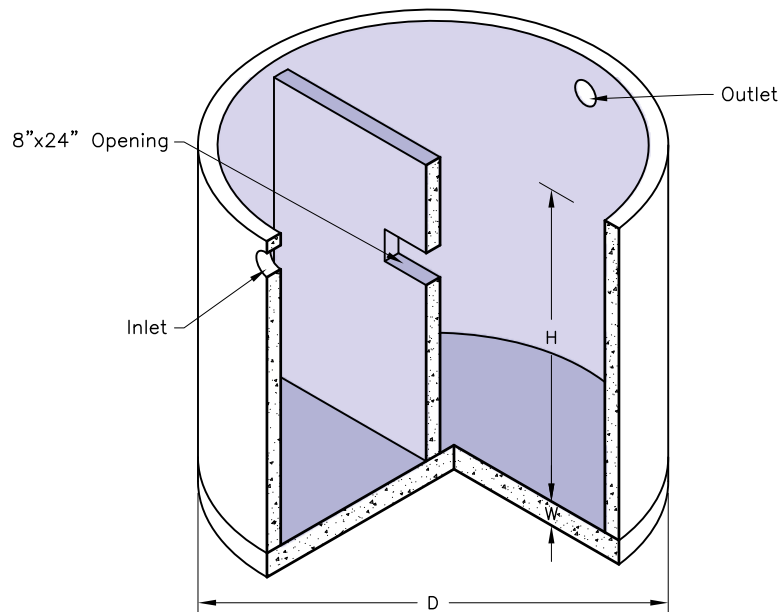

Dome

Body

SEPTIC TANK SPECIFICATIONS			
LIQUID CAP/GAL	"D"	"H"	"W"
1200	8'-0"	5'-0"	6"
* 1500	8'-0"	6'-0"	6"
* 1800	8'-0"	7'-0"	6"
2000	10'-0"	5'-0"	6"
* 2500	10'-0"	6'-0"	6"
* 3000	10'-0"	7'-0"	6"
* 3750	12'-0"	6'-0"	8"
* 4500	12'-0"	7'-0"	8"
* 5250	12'-0"	8'-0"	8"

* Wall Section is in Two Pieces, Not One Piece

SPECIFICATIONS:

1. Concrete: 28 Day Compressive Strength $f'_c = 4,000$ psi.
2. Steel reinforcement: ASTM A-615, Grade 60, ASTM A-185.
3. Designed for AASHTO HS-20 loading with 24" cover.
4. Piping by others.