

60"Ø X 3'-2" FIXED HEIGHT  
WITH 5" ANTI FLOAT BASE  
BASE WEIGHT: 7,930 LBS

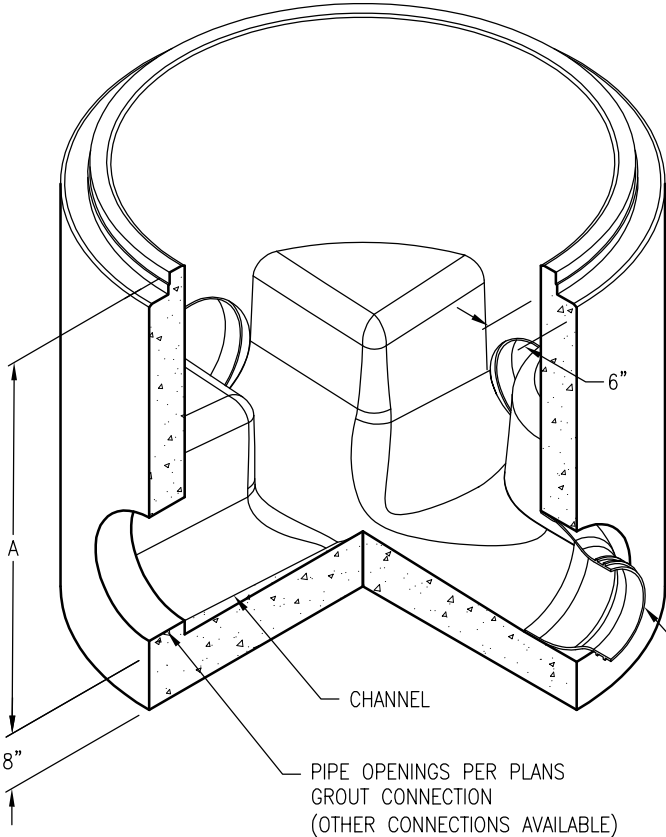

60"Ø BASE		
BASE DIA.	A	WEIGHTS LBS.
60"	24"	5,855
60"	30"	6,515
60"	36"	7,176
60"	42"	7,836
60"	48"	8,497
60"	54"	9,157
60"	60"	9,818
60"	66"	10,478
60"	72"	11,139

DRAWING MAY NOT CONFORM TO THE MOST CURRENT SPECIFICATION



**Oldcastle Precast**®

Northern California

Madera ■ Morgan Hill ■ Pleasanton ■ Santa Rosa ■ Stockton ■ Tulare  
Phone: 925-750-6650 Fax: 925-750-6660

60"Ø MANHOLE

FILE NAME: MH-24.DWG

REVISED: MARCH 2016

[www.oldcastleprecast.com](http://www.oldcastleprecast.com)

60"Ø BASES  
SANITARY SEWER  
MANHOLES

Copyright © 2016 Oldcastle Precast, Inc.