

MONOLITHIC BOX CULVERTS

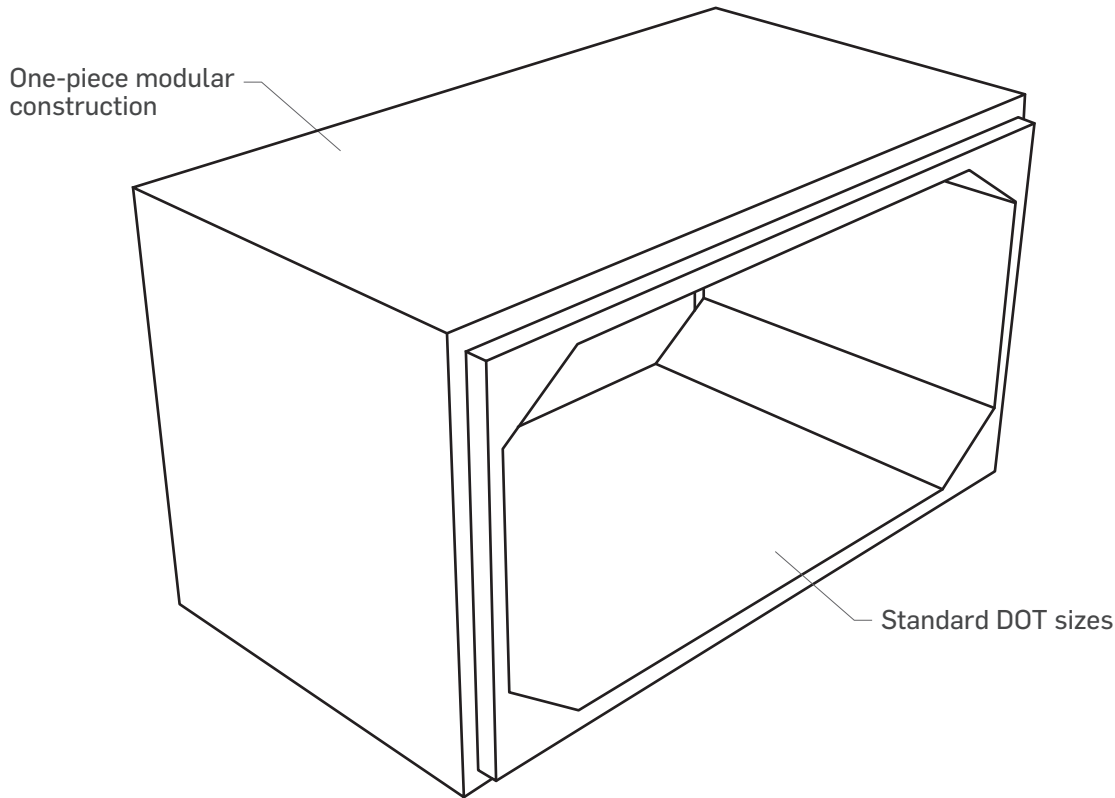

APPLICATIONS

- > Bridge & crossings
- > Stormwater management
- > Pedestrian/golf tunnel
- > Industrial conveyance/storage

FEATURES

- Standard DOT dimensions
- Long lay-lengths
- Wide flow – low hydraulic head
- Less flow-way obstruction
- AASHTO – LRFD design, ASTM C 1786

BENEFITS

- Interchangeable with monobox
- Less construction time
- Less fill – vertical curve
- Less maintenance cost
- Cooper E-80, FAA AC150 available



For more information please contact our National Sales Office at **(888) 965-3227** or send an email to contactprecast@oldcastle.com. *Verify specific availability at local facilities.*

OLDCASTLE PRECAST – TRANSPORTATION GROUP

The Oldcastle Precast Transportation Group in the Eastern US offers components that assist in the *acceleration of bridge and highway construction projects.*

The US Department of Transportation Federal Highway Administration stated in in 2015 that **one fourth** of the Nations 600,000 bridges require work or replacement. The agency has championed various programs to encourage the development of new and better ways to get infrastructure projects planned, designed, built and maintained see www.fhwa.dot.gov/innovation/resources/.

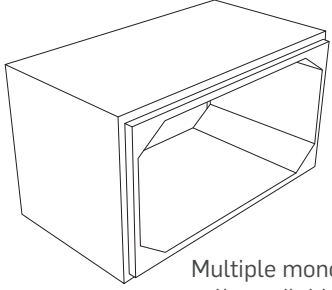
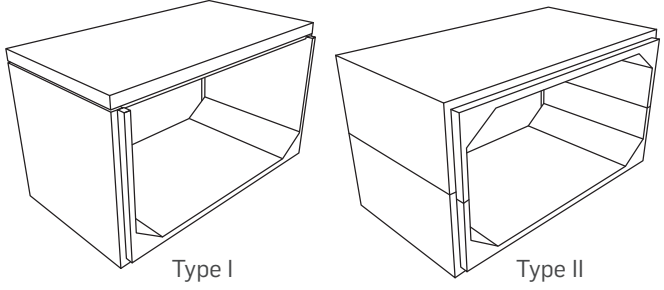
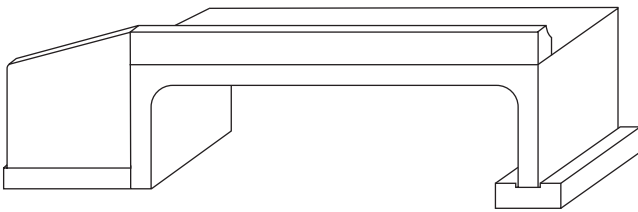
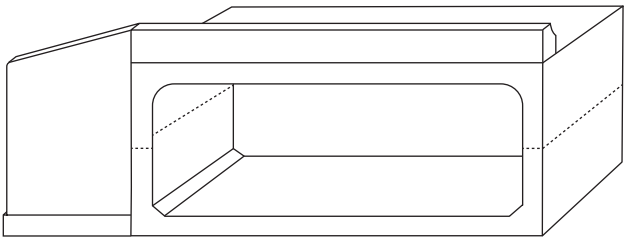
<p>Monolithic Box Culverts</p>  <p>Multiple monolithic cells available</p>	<p>Segmental Box Culverts</p>  <p>Type I Type II</p>
<p>Rigid Span Bridge</p> 	<p>Rigid Span Bridge-Type II</p> 

- > **Factory built precast concrete**
- > **Rapid installation**

- > **Transported to the site/ready to install**
- > **Accelerated productivity**

INCREASE

Safety

Quality

Durability

DECREASE

Construction time

Environmental impact

Public inconvenience