

Various Size ϕ Anchor Bolts(4)

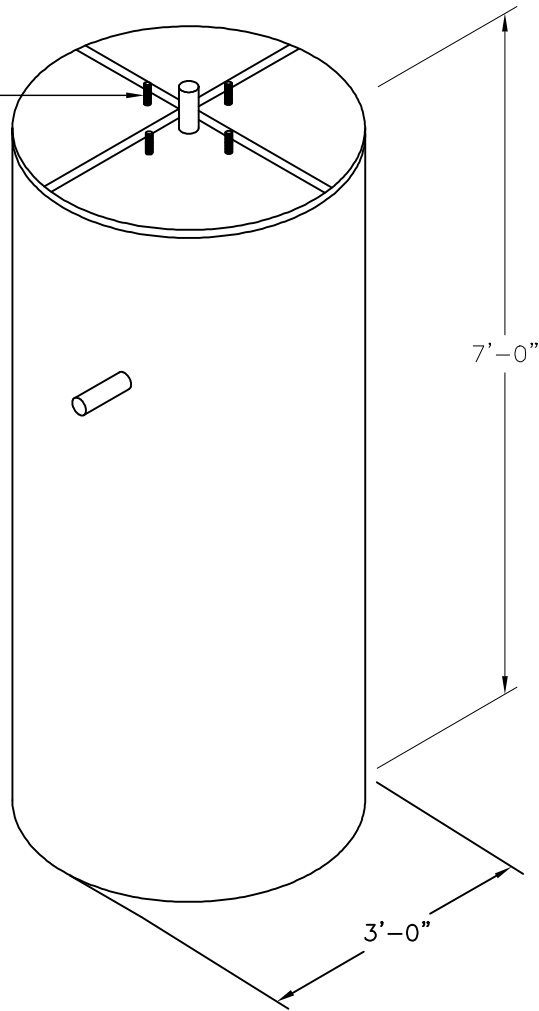

Oldcastle Precast[®]

LPB36D-7

FILE NAME: 325UEFLPB36-7_ISO.DWG

ISSUE DATE: January, 2008

www.oldcastleprecast.com

**3'-0" Dia. x 7'-0"
Light Pole Base
MHD Standard
7,500 Lbs.**

Copyright © 2008 **Oldcastle Precast**[®]

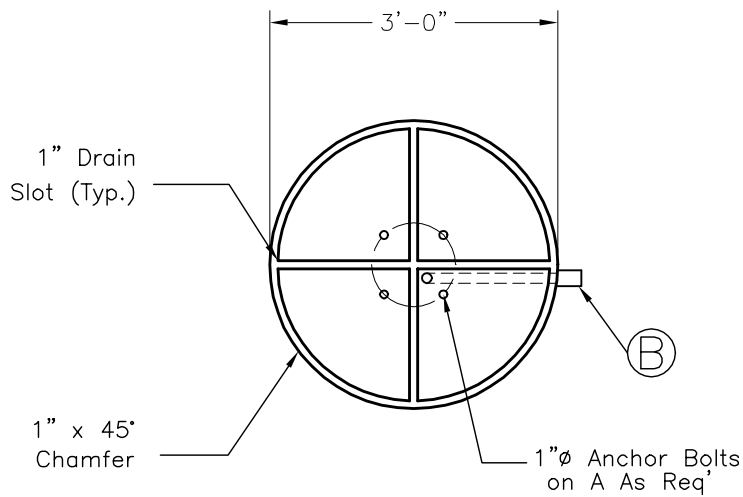

PLAN VIEW \emptyset Bolt Circle

GENERAL NOTES:

1. Concrete: 28 Day Compressive Strength $f'_c = 5,000$ psi. Type III
2. Rebar: Grade 60 Per ASTM A615. (Epoxy).
3. Sweep will not Extend Further than 3" from Side of Base.
4. For MHD. all Sweeps Must be One Piece Galvanized Construction.

DATA CHART

LTRQTY	Description
(A) 4	1" \emptyset x 36" Long Anchor Bolt (Galv.)
(B) 1	\emptyset x Long Sweep (Galv.)

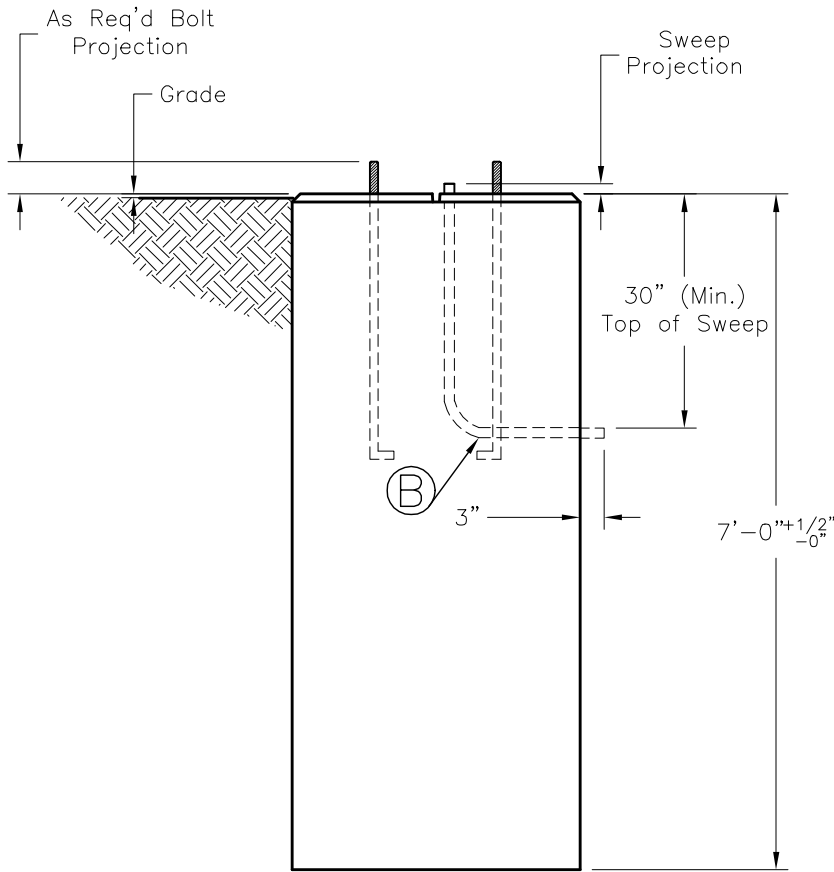

ELEVATION VIEW



LPB36D-7

FILE NAME: 325UEFLPB36-7_DET.DWG

ISSUE DATE: January, 2008

www.oldcastleprecast.com

**3'-0" Dia. x 7'-0"
Light Pole Base
MHD Standard
7,500 Lbs.**

Copyright © 2008 **Oldcastle Precast**