

FD4X8-S

FILE NAME: 324ESGFD4X8-S_ISO.DWG

ISSUE DATE: January, 2008

www.oldcastleprecast.com

4'-0" x 8'-0" x 1'-6"
FDS Flowdiffusor

Copyright © 2008 **Oldcastle** Precast

GENERAL NOTES:

1. Concrete: 28 Day Compressive Strength $f'_c = 4,000$ psi
2. Steel Reinforcement: ASTM A-615, Grade 60
3. Cover to Steel-1" Minimum
4. Design Loading-HS-20
5. Earth Cover-1 to 5 Feet Max.
6. Construction Joint-Lapped
7. Approximate Wt. = 1.20 Tons

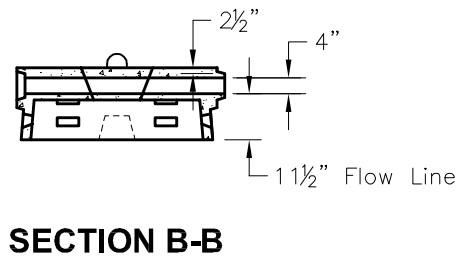
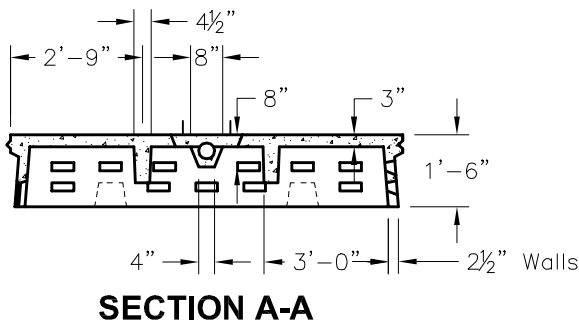
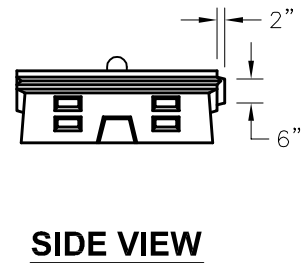
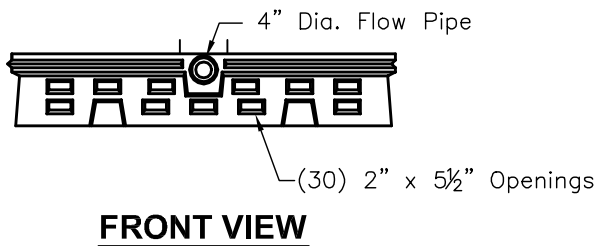
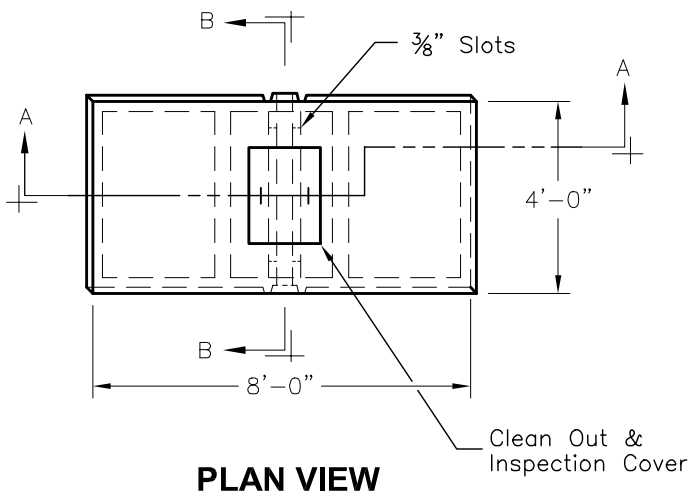

Oldcastle Precast[®]

FD4X8-S

FILE NAME: 324ESGFD4X8-S_DET.DWG

ISSUE DATE: January, 2008

www.oldcastleprecast.com

4'-0" x 8'-0" x 1'-6"
FDS Flowdiffusor

Copyright © 2008 **Oldcastle Precast**[®]